

Owner's Manual

READ THIS MANUAL CAREFULLY,
IT CONTAINS IMPORTANT SAFETY INFORMATION.

This operation manual is made for Go-kart models:

300XRX 300XR5 GK300-1 GK300-2 HAMERHEAD300



**Minimum
Recommended
Operator Age: 18**

BV Powersports, LLC – EMISSION CONTROL SYSTEM WARRANTY

YOUR WARRANTY RIGHTS AND OBLIGATIONS

The California Air Resources Board, the U.S. Environmental Protection Agency, and BV Powersports LLC (hereinafter “distributor”) are pleased to explain the emission control system warranty on your 2011 Off-Road ATV.

New off-road motor vehicles must be designed, built and equipped to meet U.S. EPA Federal and California anti-smog standards. Distributor must warrant the emission control system on your vehicle for 5,000 km, 500 hours of engine operation, or at least 30 months, whichever comes first, provided that there has been no abuse, neglect or improper maintenance of your vehicle. This ATV was designed to meet the emission standards for 10,000 km, 1,000 hours of engine operation, or five years, whichever comes first.

Your emission control system may include parts such as the carburetor or fuel injection system, the ignition system, catalytic converter and engine computer, if it is equipped. Also included may be hoses, belts, connectors and other emission-related assemblies.

This vehicle is warranted, for its emission control devices, for the full useful life of the vehicle. Where a warrantable condition exists, Distributor will repair your vehicle at no cost to you, including diagnosis, parts and labor.

If an emission-related part on your vehicle is defective, the part will be repaired or replaced by distributor. This is your emission control system DEFECTS WARRANTY.

OWNER’S WARRANTY RESPONSIBILITIES

As the vehicle owner, you are responsible for the performance of the required maintenance listed in your owner’s manual. Distributor recommends that you retain all receipts covering maintenance on your vehicle, but Distributor cannot deny warranty solely for the lack of receipts or for your failure to ensure the performance of all scheduled maintenance.

You are responsible for presenting your vehicle to the Distributor dealer as soon as a problem exists. The warranty repairs should be completed in a reasonable amount of time, not to exceed 30 days.

As the vehicle owner, you should be aware that Distributor may deny your warranty coverage if your vehicle or a part has failed due to abuse, neglect, improper maintenance or unapproved modifications.

If you use your vehicle in any type of competitive event, this warranty is immediately and completely void.

If you have any questions regarding your warranty rights and responsibilities, you should contact distributor at 2848 Reward, Dallas, TX 75220, the U.S. Environmental Protection Agency, 2000 Traverwood Avenue, Ann Arbor, MI 48105 or, (for California registered off-road vehicles only) the California Air Resources Board at 9528 Telstar Avenue, El Monte, CA 91731.

BV Powersports, LLC – EMISSION CONTROL SYSTEM WARRANTY

YOUR WARRANTY RIGHTS AND OBLIGATIONS

BV Powersports, LLC (hereinafter “Distributor”) warrants that each new 2011 and later Distributor off-road vehicle:

A. is designed, built and equipped so as to conform at the time of initial retail purchase with all applicable regulations of the United States Environmental Protection Agency, and the California Air Resources Board; and

B. is free from defects in material and workmanship which cause such vehicle to fail to conform to applicable regulations of the United States Environmental Protection Agency or the California Air Resources Board for the periods specified above.

The warranty period begins on the date the vehicle is delivered to the initial retail purchaser, or on the date the vehicle is first placed in service as a demonstrator, rental, lease prior to retail sale.

I. Coverage. Warranty defects shall be remedied during customary business hours at any authorized Distributor dealer located within the United States of America in compliance with the Clean Air Act and applicable regulations of the United States Environmental Protection Agency and the California Air Resources Board. Any part or parts replaced under this warranty shall become the property of Distributor.

II. Limitations This Emission Control System Warranty shall not cover any of the following:

A. Repair or replacement as a result of

- (1) accident,
- (2) misuse,
- (3) repairs improperly performed or replacements improperly installed,
- (4) use of replacement parts or accessories not conforming to specifications set forth by Distributor, which adversely affect performance and/or
- (5) use in competitive racing or related events.

B. Inspections, replacement of parts and other services and adjustments required for required maintenance.

C. Any vehicle equipped with an odometer or hour meter on which the odometer mileage or hour meter reading has been changed so that actual mileage cannot be readily determined.

III. Limited Liability

A. The liability of Distributor under this Emission Control System Warranty is limited solely to the remedying of defects in material or workmanship by an authorized Distributor dealer at its place of business during customary business hours. This warranty does not cover inconvenience or loss of use of the vehicle or transportation of the vehicle to or from the Distributor or authorized dealer. Distributor shall not be liable for any other expenses, loss or damage, whether direct, incidental, consequential or exemplary arising in connection with the sale or use of or inability to use the distributor vehicle for any purpose. Some states do not allow the exclusion or limitation of any incidental or consequential damages, so the above limitations may not apply to you.

BV Powersports, LLC – EMISSION CONTROL SYSTEM WARRANTY

YOUR WARRANTY RIGHTS AND OBLIGATIONS

- B.** No express emission control system warranty is given by Distributor, except as specifically set forth herein. Any emission control system warranty implied by law, including any warranty of merchantability or fitness for a particular purpose, is limited to the express emission control system warranty terms stated in this warranty. The foregoing statements of warranty are exclusive and in lieu of all other remedies. Some states do not allow limitations on how long an implied warranty lasts, so the above limitations may not apply to you.

IV. LEGAL RIGHTS. This warranty gives you specific legal rights, and you may also have other rights which vary from state to state.

V. ADDITIONAL INFORMATION. Any replacement part that is equivalent in performance and durability may be used in the performance of any maintenance or repairs. However, distributor is not liable for these parts. The owner is responsible for the performance of all required maintenance. Such maintenance may be performed at a service establishment or by any individual.

This warranty is in addition to the Distributor limited vehicle warranty.

No dealer is authorized to modify this Limited Emission Control System Warranty issued by Distributor.

OWNER'S MANUAL

Page

- 1. FOREWORD1
- 2. A FEW WORDS ABOUT SAFETY.....2
- 3. IMPORTANT SAFETY INFORMATION.....3
- 4. SAFETY LABELS.....5
- 5. ARE YOU READY TO DRIVE?.....6
- 6. IS YOUR VEHICLE READY TO DRIVE?.....7
- 7. SAFE DRIVING PRECAUTIONS.....8
- 8. P.D.I.....10
- 9. SPECIFICATIONS.....11
- 10. OPERATION.....13
- 11. SERVICE INSTRUCTIONS.....17
- 12. REPAIR.....20
- 13. PERIODICAL CHECK AND SERVICES.....23
- 14.WIRING DIAGRAM.....24

Thank you for purchasing our Kart. We hope you will enjoy it. Before you start to operate the kart, please read through this Owner's Manual carefully as it contains important safety and maintenance information. Failure to follow the warnings contained in this manual can result in serious injuries. Or death

Be sure to follow the recommended maintenance schedule and service your kart accordingly. Preventive maintenance is extremely important to the longevity of your kart.

Beginners should seek instruction from their dealer or qualified instructors before and during initial use of the kart. It is also recommended to practice in a large flat open area to familiarise yourself with operations of this kart.

We hope you will have a pleasant experience with our products and thank you again for choosing our kart.

A FEW WORDS ABOUT SAFETY

In order to keep everyone safe, you must take responsibility for the safe operation of your kart.

To help you make informed decisions about safety, we have provided operating procedures and other information on labels and in this manual. This information alerts you to potential hazards that could hurt you or others.

It is not practical or possible to warn you about all hazards associated with operating or maintaining a kart. You must use your own good judgment.

You will find important safety information in a variety of forms, including:

Safety Labels - On the kart.

Safety Messages - preceded by a safety alert symbol  and one of two signal words: **WARNING**, or **CAUTION**.

These signal words mean:



Physical harm may result from failure to adhere to the instructions that are described within the WARNING labels.

Safety Headings - such as Important Safety Reminders or Important Safety Precautions.

Safety Section - such as Kart Safety.

Instructions - how to use this kart correctly and safely.

This entire manual is filled with important safety information-please read it all carefully.

Your kart will provide you with many years of use and pleasure. Providing you take responsibility for your own safety and that of any one else using your kart or near to the kart when it is being used and understand the challenges you can meet while driving.

There is much that you can do to protect yourself while operating your kart. You will find many helpful recommendations throughout this manual. The following are a few that we consider to be the most important.

Follow the Age Recommendation

The kart should not be driven by anyone under the age of 16.

Always Wear a Helmet

It's a proven fact: helmets significantly reduce the number and severity of head injuries. Always wear an approved motorcycle helmet. We also recommend that you wear eye protection, sturdy boots, gloves, and other protective gear.

Drive Off-Road Only

Your kart is designed and manufactured for off-road use only. The tires are not made for use on pavements, and the kart does not have turn signals and other features required for use on public roads. If you need to cross a paved or public road, get off and walk your kart across.

Take Time to Learn & Practice

Even if you have driven other karts, take time to become familiar with how this kart works and handles. Practice in a safe area until you build your skills and get accustomed to this kart's size and weight.

Because many accidents involve inexperienced or untrained drivers, we urge all drivers to take a training course. Check with your dealer for more information on training courses.

Be Alert for Off-Road Hazards

The terrain can present a variety of challenges when you drive off-road. Continually "read" the terrain for unexpected turns, drop-offs, rocks, ruts, and other hazards. Always keep your speed low enough to allow time to see and react to hazards.

IMPORTANT SAFETY INFORMATION

Drive within Your Limits

Pushing limits is another major cause of kart accidents. Never drive beyond your personal abilities or faster than conditions warrant. Remember that alcohol, drugs, fatigue, and inattention can significantly reduce your ability to make good judgments and drive safely.

Don't Drink and drive

Alcohol and driving don't mix. Even one drink can reduce your ability to respond to changing conditions, and your reaction time gets worse with every additional drink. So don't drink and drive, and don't let your friends drink and drive either.

Do not operate this kart at night.

Operating in the dark vision can greatly reduce a driver's visibility and judgment. So driving at night is dangerous and can increase the possibility for an accident.

Never run your kart indoors.

The exhaust from the engine contains a tasteless, odorless and poisonous gas called carbon monoxide.

Keep away from moving parts of the kart

The operator of the kart should never place their hands or other parts of their body near any moving part of the kart. Failure to adhere to this warning will cause physical harm to your body.

Skidding or Sliding

The terrain surface can be a major factor affecting turns. Skidding in a turn is more likely to occur on slippery surfaces such as snow, ice, mud and loose gravel. If you skid on ice, you may lose all directional control. To avoid skidding on slippery terrain, keep your speed low and drive carefully.

This section presents some of the most important information and recommendations to help you drive your kart safely. Please take a few moments to read these pages.

The labels should be considered permanent parts of the kart. If a label comes off or becomes hard to read, contact your dealer for a replacement.

WARNING

Do not shift gears when the vehicle is in motion or it might cause damage to the transmission and void warranty. Shift only when the footbrake is fully engaged and the vehicle is at a complete stop.

WARNING

ALWAYS CHECK HEADLAMP OIL AND REPLACE AS NEEDED. IF NOT DONE SO YOU FAN THE CHANGE OF BURNING THE HEADLAMP AND COSTLY REPAIRS.



WARNING

YOUR ENGINE IS WATER COOLED! YOU MUST CHECK THE RADIATOR CAP OFFER TO SEE IF THE LEVEL OF THE COOLANT IS FULL. UNHOT REFILL AS NEEDED IF YOU DO NOT DO THIS YOUR ENGINE COULD BURN UP AND COST YOU A REPAIR. NEVER OPEN THE RADIATOR CAP WHEN ENGINE IS RUNNING ALLOW THE ENGINE TO COOL DOWN.

WARNING

OIL CHECK
AFTER RUNNING YOUR KART EVERY 4 HOURS, YOU NEED TO CHECK YOUR ENGINE/GEAR BOX OIL. FAILURE TO DO SO CAN CAUSE ENGINE DAMAGE.

COOLANT CHECK
AFTER RUNNING YOUR KART EVERY 5 HOURS, YOU NEED TO CHECK YOUR COOLANT FLUID. FAILURE TO DO SO CAN CAUSE ENGINE DAMAGE. NEVER CHECK YOUR COOLANT WHEN ENGINE IS RUNNING ALWAYS ALLOW ENGINE TO COOL DOWN BEFORE CHECKING.

WARNING

NO LONG HAIR



ALL HAIR MUST BE TIED UP AND SECURED AT OR ABOVE SHOULDER LENGTH. ALL LOOSE CLOTHING MUST BE SECURED. ALL NECKLACES AND SCARVES MUST BE SECURED.

WARNING

THIS GO-KART CAN BE HAZARDOUS TO OPERATE if driven carelessly.

IN JURIES can result if you do not follow these INSTRUCTIONS:

- READ OWNERS MANUAL AND ALL LABELS BEFORE YOU OPERATE THIS GO-KART.
- NEVER OPERATE THIS GO-KART WITHOUT PROPER INSTRUCTIONS. Beginners require adult supervision.
- NEVER OPERATE THIS GO-KART ON PUBLIC ROADS. It is intended for off-road use only.
- ALWAYS WEAR AN APPROVED MOTORCYCLE HELMET. eye protection and protective clothing.
- NEVER OPERATE THIS GO-KART AT EXCESSIVE SPEEDS. You increase your risk of losing control if you operate it at speeds too fast for the terrain, visibility conditions or your experience.
- NEVER ATTEMPT WHEELIES, JUMPS, OR OTHER STUNTS.

303115

WARNING

NO RIDING



WARNING

Loss of control, collision, or getting caught in moving parts can result in serious injuries.

Not to be operated by person under 16 years old
Wear a D.O.T. approved motorcycle helmet
Secure long hair and loose clothing
wear protective eye wear and clothing
keep arms, legs and feet inside kart
Do not use alcohol or drugs

3031107

CAUTION

THIS VEHICLE MANUFACTURED FOR OFF-ROAD USE ONLY. DO NOT OPERATE ON PUBLIC STREETS, ROADS OR HIGHWAYS.

WARNING

Seat Belt Must Be Worn At All Times

3031105

ARE YOU READY TO DRIVE?

Before each drive, you need to make sure that you and your kart are both ready to drive. To help get you prepared, this section discusses how to evaluate your driving readiness, what items you should check on your kart, and adjustments to make for your comfort, convenience, of safety.

Before you drive your kart for the first time, we urge you to:

- Read this owner's manual and the labels on your kart carefully.
- Make sure you understand all the safety messages.
- Know how to operate all the controls.

Before each drive, be sure:

- You wear your seat belt at all times while driving your kart.
- You feel well and are in good physical and mental condition.
- You are wearing an approved motorcycle helmet (with chin strap tightened securely), eye protection, and other protective clothing.
- You don't have any alcohol or drugs in your system.

Protective Apparel

For your safety, we strongly recommend that you always wear an D.O.T. Approved motorcycle helmet, eye protection, boots, gloves, long pants, and long-sleeved shirt or jacket whenever you drive.

Although complete protection is not possible, wearing proper gear can reduce the chance of injury should you have an accident.

The following suggestions will help you choose the proper protective gear.

Helmets and Eyes Protection

Your helmet is your most important piece of protective gear because it offers the best protection against head injuries. A helmet should fit your head comfortably and securely.

An open-face helmet offers some protection, but a full-face helmet offers more. Regardless of the style, look for a D.O.T. (Department of Transportation) sticker on any helmet you buy. Always wear a face shield or goggles to protect your eyes and help your vision.



Operating this kart without wearing an approved motorcycle helmet, eye protection, and protective clothing could increase your chances of head and/or eye injury, and the possibility of death in the event of a severe accident. Always wear an approved motorcycle helmet that fits properly and wear eye protection (goggles or face shield), gloves, boots, long-sleeved shirt or jacket and long pants.

ARE YOU READY TO DRIVE?

Additional Driving Gear

In addition to a helmet and eye protection, we also recommend:

- Sturdy off-road motorcycle boots to help protect your feet, ankles, and lower legs.
- Off-road motorcycle gloves to help protect your hands.
- Driving pants with knee and hip pads, a driving jersey with padded elbows, and a chest/shoulder protector.

Driver Training

Developing your driving skills is an on-going process. Even if you have driven other karts, before take time to become familiar with how this kart works and handles. Practice driving the kart in a safe area to develop your skills. Do not drive on rough terrain until you get accustomed to the kart's controls, and feel comfortable with its size and weight.



WARNING

Operating this kart without your seat belt could cause you to be thrown from the kart, causing serious injury or death.

No Alcohol or Drugs

Alcohol, drugs and karts don't mix. Even a small amount of alcohol can impair your ability to operate a kart safely. Likewise, drugs—even if prescribed by a physician—can be dangerous while operating a kart. Consult your doctor to be sure it is safe to operate a vehicle after taking medication.



WARNING

Operating this kart after consuming alcohol or drugs can seriously affect your judgment, cause you to react more slowly, affect your balance and perception, and could result in serious injury or death.

Never consume alcohol or drugs before or while operating this kart.

IS YOUR VEHICLE READY TO DRIVE?

Before each drive, it is important to inspect your kart and make sure any problems you find are corrected. A pre-drive inspection is a must, not only for safety, but because having a break down, or even a flat tire, can be a major inconvenience.

If your kart has overturned or has been involved in a collision, do not drive it until your kart has been inspected by your dealer. There may be damage or other problems that you can not see.



WARNING

Improperly maintaining this kart or failing to correct a problem before driving can cause a crash in which you can be seriously hurt or killed.

Always perform a pre-drive inspection before every drive and correct any problems.

Pre-Drive Inspection

Always carry out the Pre-Drive Inspection detailed on Page 16 before getting in your kart.

SAFE DRIVING PRECAUTIONS

Off-Road Use Only

Your kart and its tires are designed and manufactured for off-road use only, not for use on paved surfaces. Driving on paved surfaces can affect the kart handling and control. You should not drive



WARNING

Operating this kart on paved surfaces may seriously affect handling and control of the kart, and may cause the vehicle to go out of control.

Never operate the kart on any paved surfaces, including pavements, driveways, car parks and streets.

When driving off-road, also remember to always obey local off-road driving laws and regulations. Obtain permission to drive on private property. Avoid posted areas and obey “no trespassing” signs.

You should never drive your kart on public streets, roads or highways, even if they are not paved. Drivers of street vehicles may have difficulty seeing and avoiding you, which could lead to a collision. In many states it is illegal to operate karts on public streets, roads and highways.



WARNING

Operating this kart on public streets, roads or highways could cause a collision with another vehicle.

Never operate this kart on any public streets, roads or highways, whether they are dirt, gravel or paved surfaces.

Keep Hands and Feet on Controls

When driving your kart, always keep both hands on the steering wheel and both feet on the foot controls. It is important to maintain your balance and to control the kart. Removing hands or feet away from the controls can reduce your ability to react and control the kart.



WARNING

Removing your hands from the steering wheel or feet from the foot controls during operation can reduce your ability to control the kart or could cause you to lose your balance and fall off the kart.

Always keep both hands on the steering wheel and both feet on the foot controls of your kart during operation.

Control Speed

Driving at excessive speed increases the chances of an accident. In choosing an appropriate speed, you need to consider the capability of your kart, the terrain, visibility and other operating conditions, plus your own skill and experience.



WARNING

Operating this kart at excessive speeds increases your chances of losing control of the kart, which can result in an accident.

Always drive at a speed that is appropriate for your kart, the terrain, visibility and other operating conditions, and your experience.

Use Kart on Unfamiliar or Rough Terrain

Before driving in a new area, always check the terrain thoroughly, Don't drive fast on unfamiliar terrain or when visibility is limited (it's sometimes difficult to see obstructions like hidden rocks, bumps, or holes in time to react).



WARNING

Failure to use extra care when operating this kart on unfamiliar terrain could result in the kart overturning or going out of control.

Go slowly and be extra careful when operating on unfamiliar terrain. Always be alert to changing terrain conditions when operating the kart.

Never drive past the limit of visibility. Maintain a safe distance between your kart and other off-road vehicles. Always exercise caution and use extra care on rough, slippery and loose terrain.



WARNING

Failure to use extra care when operating on excessively rough, slippery or loose terrain could cause loss of traction or vehicle control, which could result in an accident, including an overturn.

Do not operate on excessively rough, slippery or loose terrain until you have learned and practiced the skills necessary to control the kart on such terrain. Always be especially cautious on these kinds of terrain.

Do Not Perform Stunts

You should always operate your kart in a safe and reasonable manner. When driving, always keep all four wheels on the ground.



WARNING

Attempting wheelies, jumps, and other stunts increases the chance of an accident, including an overturn.

Never attempt stunts, such as wheelies or jumps. Don't try to show off.

Radiator Indicator Lamp

During the driving, you should always keep close contact with this red indicator lamp. This indicator lamp will tell you when your engine coolant system is getting too hot. To keep from causing any damage, you should stop the kart and turn the key off. Check if there is any leak, At this time do not open the radiator cap, allow your coolant system and engine to cool down before opening the radiator cap.

If you find the coolant completely gone, you should check if the radiator, hoses or engine has any leaks.

P.D.I.

- A. Install RR. Shocks and tighten the unts.
- B. Install Ball Head, Tie Rod, tighten the Castle Nut and insert the cotter Pin.
- C. Install Dust Seals, align the Ball Head Bolt, Knuckle Support to the square hole on the Lower A-Arm.
- D. Install Flange Nut and tighten it (>88.9 foot lbs)
- E. Install Front Tires and tighten the nuts.
- F. Install Rear Tires, tighten the nuts, insert cotter Pin and put on the Rubber Cover.
- G. Raise the C.B.C bar as the picture shows.
- H. Install C.B.C bar RR., put on R-Washer.
- I. Install Head-Rest.
- J. Check all nuts and bolts, wiring, cables, fuel line, switches and tire pressure.
- K. Fill battery with Acid and charge, check and fill the engine with the recommended oil.
- L. Fill fuel tank with Unleaded Gasoline, and turn on the ignition switch to start the engine.

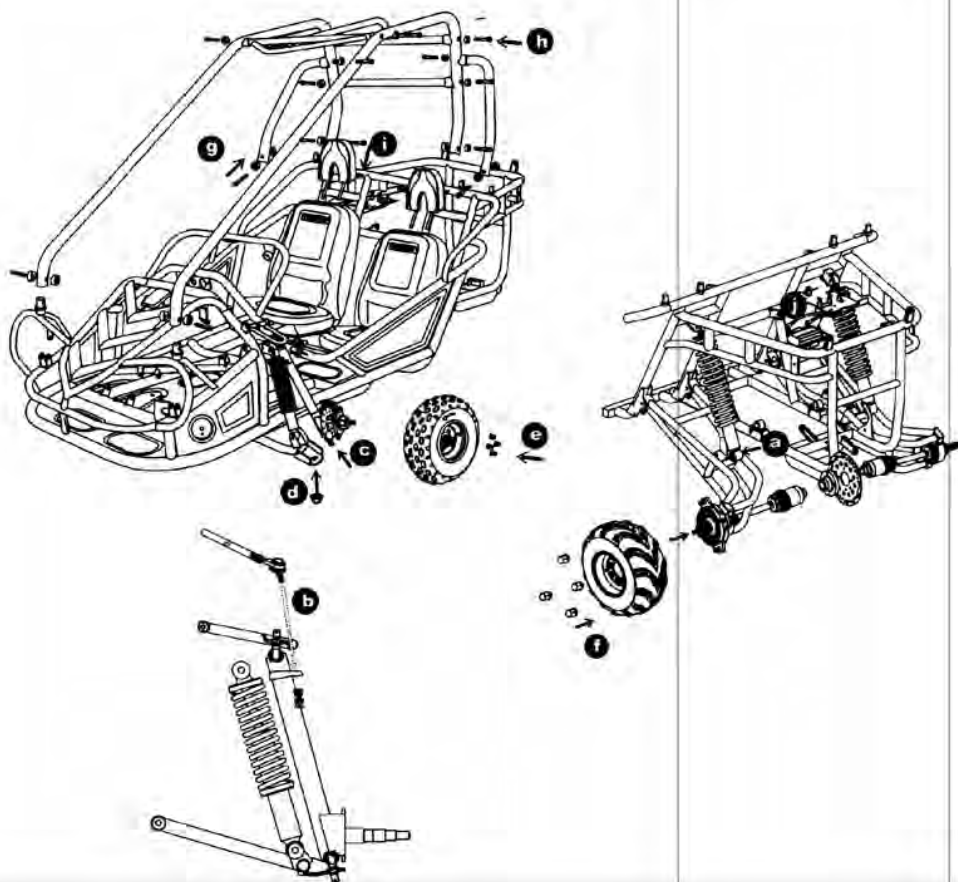

SPECIFICATIONS

DIMENSIONS

Overall Length	87 in.(2210mm)
Overall Width	53.5 in.(1346mm)
Overall Height	56.6 in.(1438mm)
Wheelbase	66.1 in.(1680mm)
Front Track	45.7in.(1160mm)
Rear Track	42.7 in.(1085mm)
Ground Clearance	8.5 in.(215mm)

ENGINE

Type	Water-cooled.4-Stroke
Engine capacity	300cc
Bore / Stroke	72.5mm x 66.8mm
Displacement	275.6cm
Corrected compression ratio	10:1
Carburetor	VEKS4 & CV30
Output Power	13KW/ 6500RPM
Maximum Torque	22N.m/5000RPM
Starting	Electri
Ignition	C.D.I
Lubrication	Force&Splash
Transmission	Automatic(C.V.T system)
Spark Plug	DR8EA(NGK)
Plug gap	0.6-0.7mm
Fuel Type	Rq90(unleaded)
Lubricate oil	SAE 15W -40/SF

DRIVE COMPONENTS

Gear box oil	MoS2 & W -2DW-4D
--------------	------------------

CAPACITIES

Maximum load	Do Uble Seats/400lbs
Fuel tank	25 Gal
Engine oil	30 Oz
Starting	5s
Climbing	20°-25°
Battery	12V 10Ah
Head Light	12V 35W /35W
Tail Light	12V 21W /5W
Fuse	10A

Brake Track.....<7m@20miles/h
Top speed.....75miles/h(or limited as customers require)

CHASSIS

Front,Rear brake..... Hydraulic disc,left foot control
Front tire20 x 7-8
Rear tire22 x 10-10
Front SuspensionIndependent Dual A-Arm
Rear Suspension..... Full Independent Rear Suspension/ Oil Damped Shock
Restraint System Dual 4-point Harness
Final Drive CV- Shafts

TIRE PRESSURE

Front.....7-9psi
Rear.....8-9psi

WEIGHT

Net Weight.....280Kg
Gross Weight 320Kg

A. Operation controls

WARNING - Do not attempt to start or operate the engine until completely familiar with the location and use of each control necessary to operate this vehicle. The operator must know how to stop this machine before starting and driving it.

a. Throttle

The right foot pedal is the throttle that controls the kart speed. As the engine speed increases above idle, the clutch automatically engages and moves the vehicle forward.

(See Fig. 1)



WARNING

Each time prior to starting the engine, check the throttle assembly to ensure that when the pedal is pushed all the way forward the assembly is working smoothly and returns to idle when released. Do not operate if pedal or engine throttle linkage fail to return to idle. If unable to correct the problem through lubrication, adjustment or replacement of worn parts, contact your dealer for assistance.

b. Brake

The brake is the left foot pedal (See Fig.1). Applying pressure to the pedal slows or stops the kart.

c. Start engine

Insert the key into key-switch, turn the key clockwise, release the key when the engine starts. The engine will warm up within 5 minutes and the choke will close automatically allowing operation at normal RPM (Warning: Don't crank the starter for more than 5 seconds at one time).

d. Engine stop button

Important-stop button test.

Before driving this vehicle, test the Engine Stop Button to ensure that it is operating properly. With the engine running, push and hold the Engine Stop Button for two seconds for the engine to shut down.

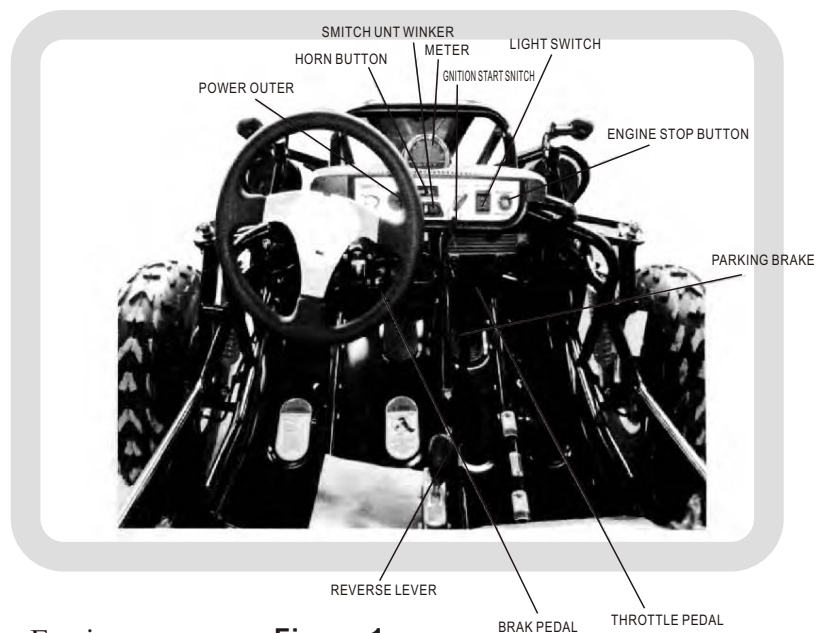

Figure 1

B. Pre-Drive Inspection



WARNING

Perform this pre-drive inspection everyday before driving the vehicle. If not performed, serious damage to the vehicle or personal injury may result.

- a. Check the engine oil level is between the bottom of the dipstick and the “0” mark, Check for leaks. Add oil if required.
- b. Check the Fuel Level. Add fuel as necessary and do not overfill. Check for leaks. Ensure the fuel filler cap is securely fastened.
- c. Check the Brakes. Depress the left brake pedal several times, and check for adequate brake pedal free play. Make sure there is no brake fluid leakage.
- d. Check the tires. Check their condition for damage or excessive wear and pressure.
- e. Check the Throttle Chain. Check for smooth operation. Ensure the throttle snaps back to idle when released and moves smoothly without sticking.
- f. Check the Engine Stop Button. While the engine is running press and hold the engine stop button for 2 seconds. Make sure the engine stops.
- g. Check all Nuts, Bolts, and Fasteners. Check the wheels to see that all axle nuts and lug nuts are tightened properly. Check and tighten as necessary all other nuts, bolts and fasteners.
- i. Check the C.B.C.Bar. Ensure all C.B.C bars are in place before operating the kart.
Check the Lights. Check the headlights, brake light and tail light are all working.
- i. Check the Steering. Check that the steering wheel moves freely in both directions but
- j. without any unusual looseness.
- k. Check all Cable Housings. Check these for wear and the fitting for any looseness.
Check the underbody and exhaust system. Remove all dirt, vegetation and mud and check
- l. for any damage due to impact with rocks or uneven terrain.
- m. Check the Air Cleaner Housing Drain Tube. Check the deposits in the drain tube. If necessary, check the tube and air cleaner housing.
- n. Check Leaks and Loose Parts. Walk around your kart and look for anything that appears unusual, such as a leak or loose cable.
- o. Check the Parking Brake. Make sure the kart does not move forward or backward when the parking barke is applied.
- p. Check the Radiator. Make sure there is no leak of radiator or hoses before you start the engine. Check the water level.
- q. Check the radiator to see if the level of the coolant is full. Refill the coolant as needed or your engine would burn up and cost you in repairs. Never open the radiator cap when engine is running. Allow the engine to cool down, and the refill the coolant.

Component locations

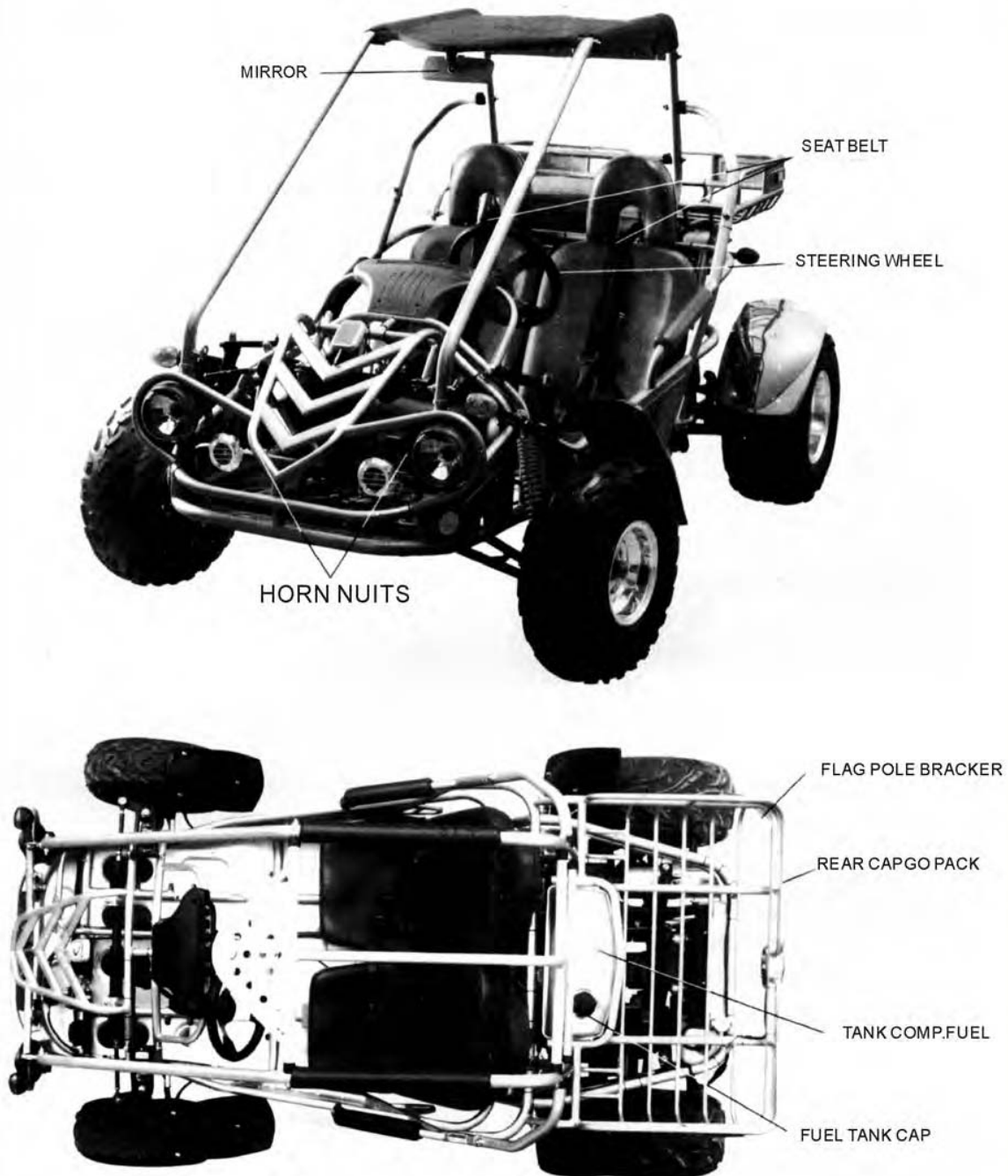

Figure 2

OPERATION

C.Passengers

The vehicle is designed for two people only. The combined maximum weight of the driver and the passenger should not exceed 200kg or 440lbs.

D.Seat Adjustment

The seat should be securely fastened in the position which gives the operator best control of the foot pedals,steering wheel,and the remote stop button.

- a.Pull the seat adjustment handle upward to disengage the seat slide.
- b.Move the seat to the desired position.
- c.Be sure that the seat adjustment handle snaps back into place and that seat is locked into position.



Figure 3



WARNING

Before attempting to adjust the seat,ensure that engine is stopped



WARNING

Never operate this kart when the seat is not securely in place, to do so could result in personal injury or loss of life.

E.Forward and Reverse Gear

- a.Push the brake pedal down.The brake pedal must be pushed in to change the gear settings.
- b.Push the lever forward to the “D” position for the kart to move forward.
- c.Each time you need to apply the brake to change the setting to go backwards apply the brake and move the lever to the “R” for the kart to go backwards note!
Your kart is set up with 3 settings(See Fig.4)

- “D” Forard
- “N” Nutraul
- “R” Revears



WARNING

Always stop the kart before changing gears.Your kart s hifter will only change after the kart is stoped and not moving!

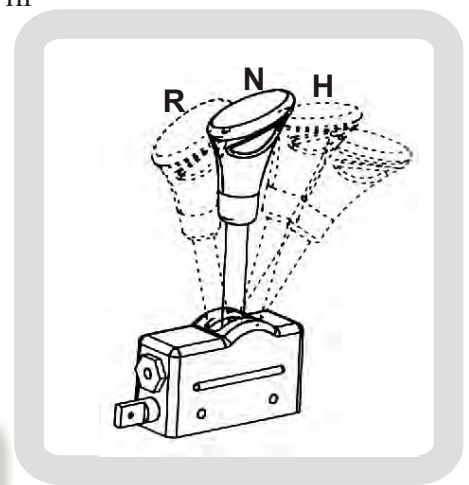

Figure 4

F.Starting and Operating Instructions

- a. Before starting the engine, the driver must be seated properly in the kart with the seat belt on.
- b. Practice in the kart in an open space at the beginning to learn how to start, turn and stop the vehicle.
- c. Drive slowly until you are familiar with the operation of the kart.
- d. The turning radius of this kart is small and agile, so the centrifugal force is very high when turning at high speed. Slow down to a more controllable speed when turning to prevent the kart from rolling over. The driver should keep their heels on the ramp of the main board when turning. (See Fig.5) Keep their leg on the foot pedal, the driver can feel that the kart is stable and won't roll over.



POSITION FOR HEEL

Figure 5

SERVICE INSTRUCTIONS

A. Air Cleaner

Service the air cleaner every 20 hours

NOTE: Service is required more often in dusty conditions.

- a. Remove cleaner cover 1.
- B. Remove air cleaner element 2 (See Fig.6)
- c. Fill the non-flammable cleaning agent into a basin and dip the element in it.
- d. Dry it after cleaning. Replace check for cracks or holes. It needs to be replaced with new filter.

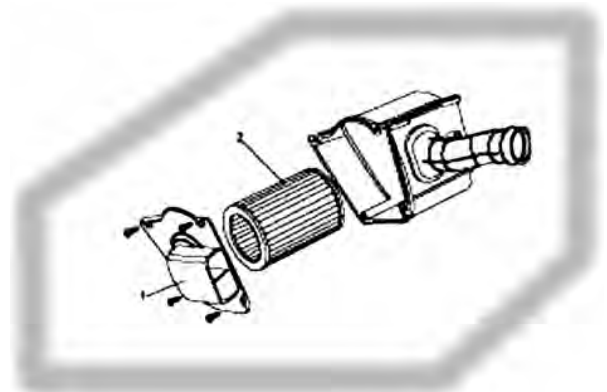

Figure 6

SERVICE INSTRUCTIONS

B. Engine Lubrication

You must change the oil in the crankcase after the first 5 hours of operating (See Fig.7) and after every 10 hours of use thereafter. This will insure proper lubrication of the internal parts and prevent costly repairs due to excessive wear.



WARNING

Used Oil Must Be disposed of at a proper collection Center

a. Remove the drain plug located on the right rear side of the engine. Tip the kart backwards slightly by blocking up the front end and drain the oil into suitable container.

b. Remove and clean the oil filter.

c. Replace the drain plug and tighten securely. Place the kart in a level position.

d. Refill the crankcase (approximately 1 1/4 pint) to the top of the filler neck with SAE 10W40 oil.

e. Check the oil level before each use of the kart or after each 10 hours of operation. Add oil when necessary to keep the level between the bottom of the dipstick and the "0" mark. Do not mix various grades of oil.

ENGINE OIL PLUG COVER

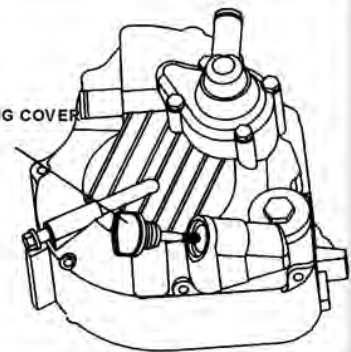

Figure 7

C. Spark Plug

a. Remove the spark plug and inspect it each time you change the oil (Use a spark plug wrench). The electrodes should be kept clean and free of carbon. The presence of carbon or excess oil will greatly reduce engine performance. If possible, check the spark plug gap (area between electrodes) using a wire feeler gauge. This specification is 0.6-0.7 mm.

b. Before installing the spark plug coat the threads lightly with graphite grease if possible, to ensure easy removal next time the spark plug needs inspection.

c. It is advisable to replace the spark plug at least once a year to ensure easy starting and good engine performance.

SEAM, DIRT, CARBON VERIFY

0.6-0.7mm

WASHER VERIFY

SEAM VERIFY

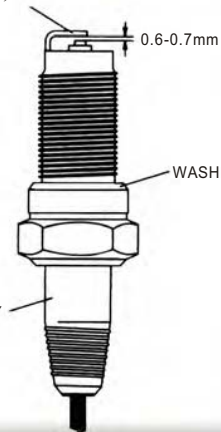

Figure 8

D. Cleaning Adjustment

Never make unnecessary adjustments. The factory recommended settings are correct for most applications.

- a. Warm up the engine (5-10min)
- b. Tighten the air screw gently. Backout 2-3/8 turns counter clockwise.
- c. Connect the tachometer, adjust the throttle to limit the idle speed. The standard value is 1400RPM
- d. Turn the air screw counter clockwise slowly and observe the RPM of the engine, stop adjusting as the RPM reaches the top speed
- e. Adjust the screw and adjust the idle speed to an ideal value.
- f. Recheck and readjust the idle speed if necessary.

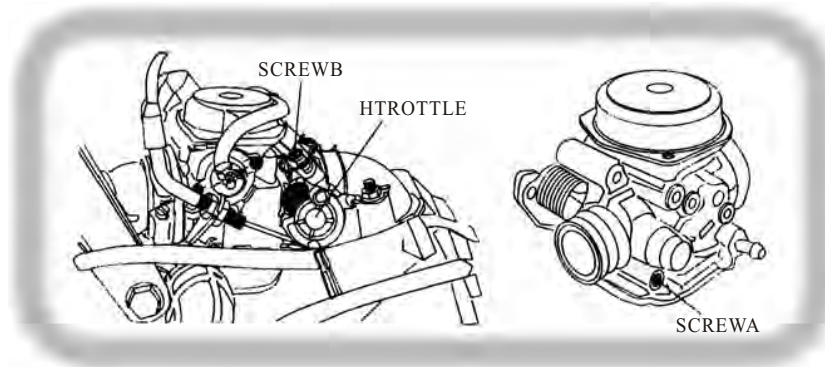

Figure 9

E. Cleaning Instructions

Keep your kart clean. With a clean rag, wipe off all dirt and oil from around the controls. Wipe off any spilled fuel and oil. Keep the engine clean of foreign objects, and be sure to check that the air intake fan is free of debris for proper cooling.

F. Kart Lubrication

Lubricate the vehicle every 90 days of use. Lubrication should be done more often, if the kart is used everyday.

G. Adjustment of Front And Rear Shock

There are five positions on each shock. The default position is the middle set by the manufacturer (see Fig. 10)

Use a round nut wrench as you adjust the shock, the tension of the shock spring will increase as you screw to the left, decrease as you screw to the right. Adjust according to the weight of the riders.

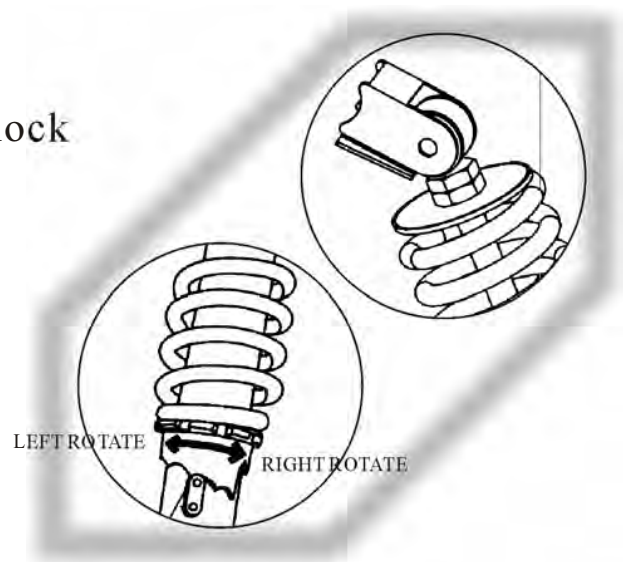

Figure 10

H.Storage Instruction

In the event your kart is not to be operated for a period in excess of 30 days or at the end of each driving season prepare for storage as follows:

- a.Drain the fuel tank and carburetor by allowing the engine to run out of fuel.
- b.Lubricate engine cylinder by removing the air spark plug and pouring a small amount of oil into the plug hole,then re-fit the plug.
- c.Do not save or store gasoline over winter.Using old gasoline,which has deteriorated from storage,will make the engine difficult to start and affect engine performance.



WARNING

Do not drain fuel while engine is hot.Be sure to move the kart outside before draining fuel.

REPAIR

A.Front Wheel Replacement

Do not disassemble the castle nuts when you replace the front wheels.

It is only necessary to remove the 4 lug nuts to remove the wheel.(See Fig.11)

Tighten the nuts after replacing the wheels.

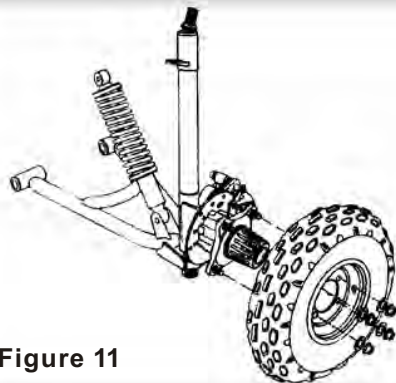

Figure 11

B. Rear Wheel Replacement

Do not disassemble the castle nuts when you replace the rear wheels and hub assembly.

Remove the cotter pin and then 24 mm nut. Then slide off the wheel and hub assembly. It is only necessary to remove the 4 lug nuts to remove the wheel. Tighten the nuts after replacing the wheels.

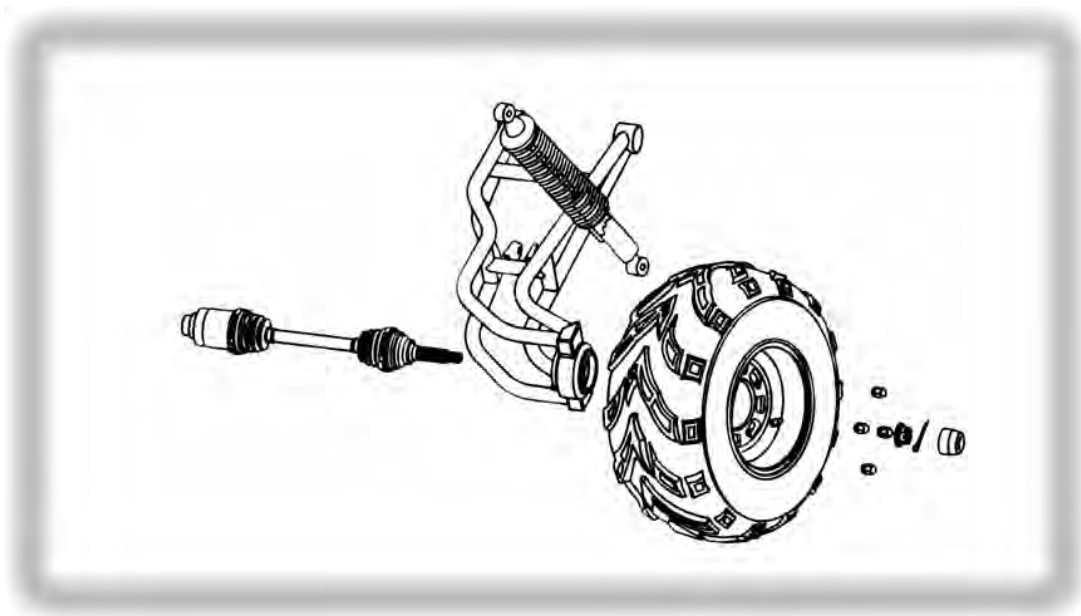

Figure 12

C. Front Wheel Alignment

a. The front wheels should be toe-in from 1/8 to 1/4 inch. To check for alignment, measure distance A and B between the centerline (CL) of the wheels. The proper toe-in dimension A should be 1/8 to 1/4 inch greater than dimension B.

b. To adjust the alignments, loosen the lock nuts on both sides of Front Tie Rods. To make Dimension B smaller, turn the rod to left. Adjust the rod to right direction to make Dimension B larger. After adjusting to the desired length, tighten the lock nut against the rod end. Recheck the dimensions for proper alignment.

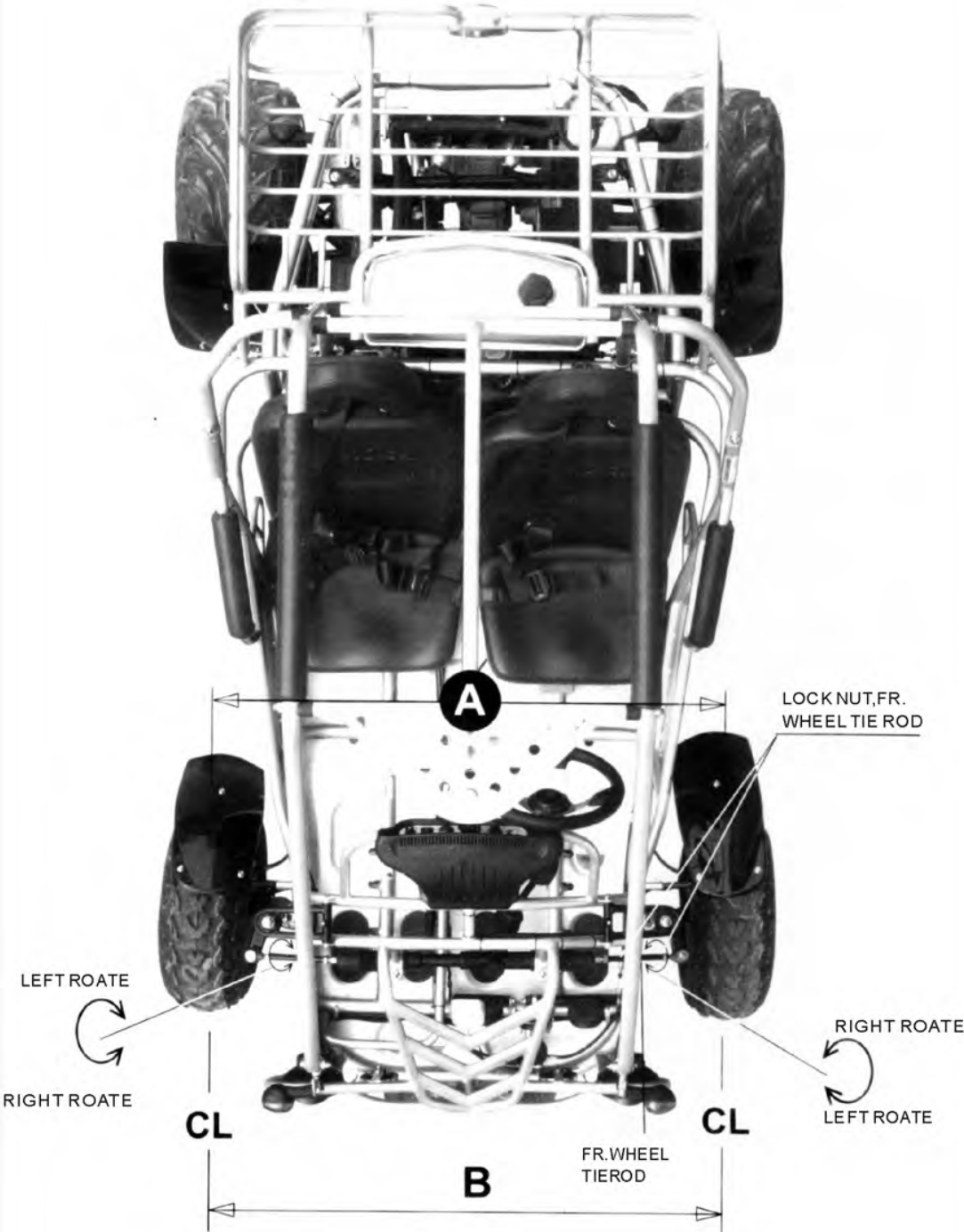

Figure 13

PERIODICAL CHECK AND SERVICES

To keep the performance good, the motorcycle should be checked and maintained at certain interval. The meanings of capital in following table are:

I: Inspection, including check, clean, lubricate, refuel, repair or replacing if necessary.

A: Adjusting C: Cleaning R: Replacing T: Tightening

Maintenance period Items	Odometer (km)												Everyday check before riding		
	300	1000	2000	3000	4000	5000	6000	7000	8000	9000	10000	11000		12000	
Crankcase lube	R	R		R		R		R					R		I
Lube filter	C				C				C					C	
Air filter	Clean filter every 2000~3000 km. change it when necessary														
Spark plug	Initial 1000km and Clean every 3000~4000km change it when necessary														
Valve gap		A			A				A						A
Cam chain		A			A				A					A	
Carburetor	I				I,C				I,C					I,C	
Gas filter									R						
Brake system		I	I	I	I	I	I	I	I	I	I	I	I	I	I
Driving chain		I							I						I
Fasteners	T					T									
Coolant	A			A		A				A				A	I
Gearbox oil	I			R		R								R	
Battery													I		

* When the mileage is over the highest on the table, please perform according to the period set on the table
 * Driving on dust place, it is recommended to clean it frequently.

GOKART250 ELECTRICITY PRINCIPLE DIAGRAM

