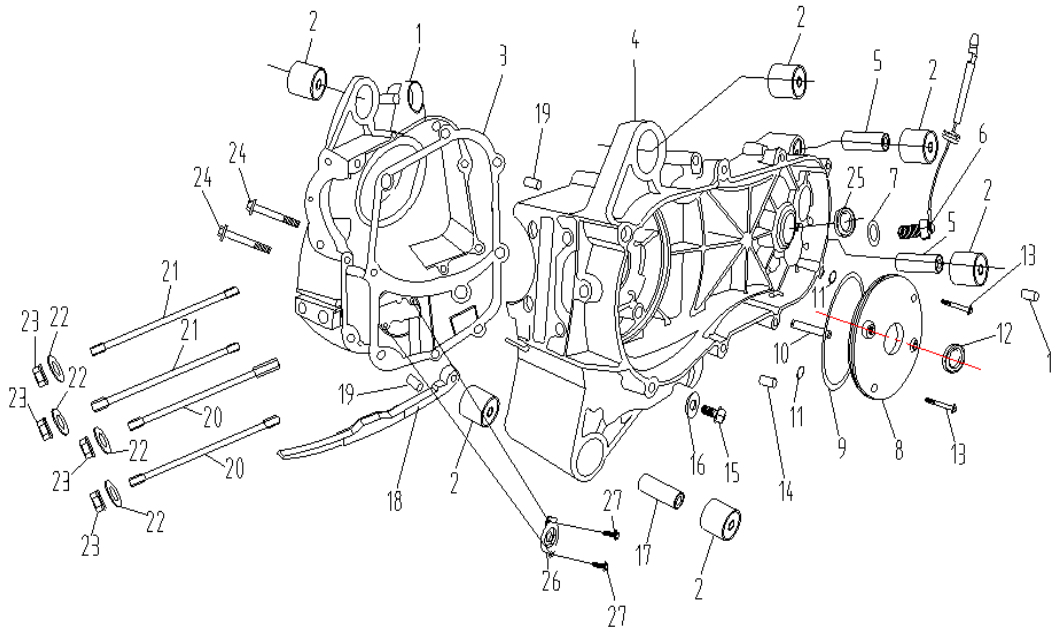




**TrailMaster UTV  
Challenger 150 PARTS MANUAL**

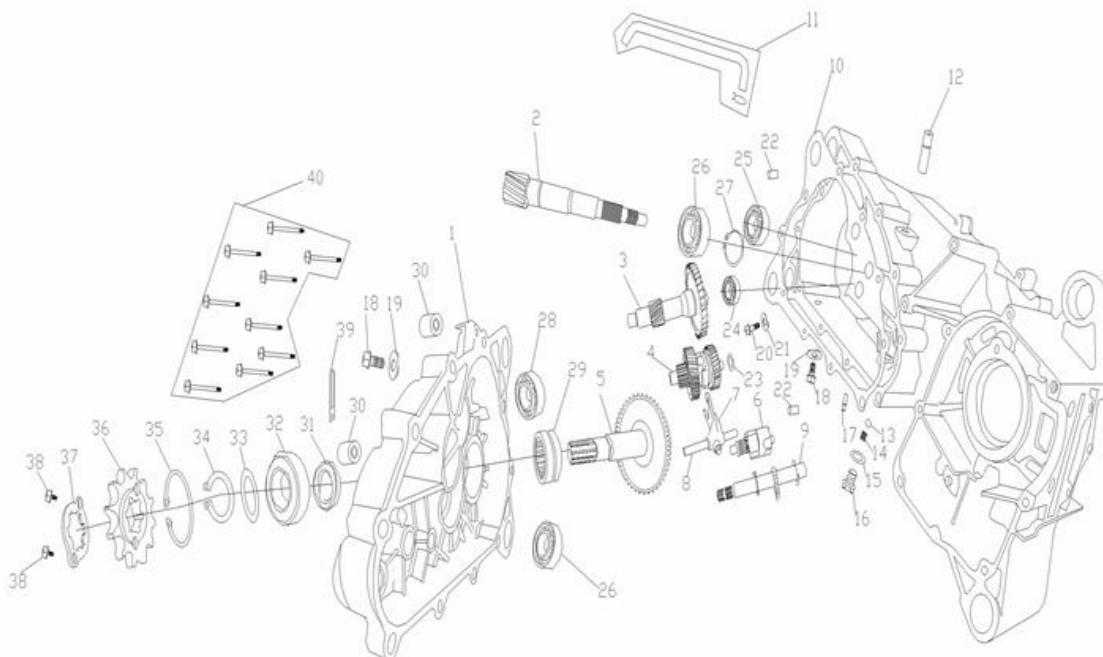
**FIG. 1 ENGINE CASE COMP.**



<b>ENGINE CASE COMP.</b>			
<b>REF NO.</b>	<b>PART NO.</b>	<b>DESCRIPTION</b>	<b>QTY</b>
1-1	157.03.002	RIGHT CASE BODY	1
1-2	157F.12.114	DAMPING BUSHING	6
1-3	152.12.301	CRANKCASE GASKET	1
1-4	157F.03.001	LEFT CRANKCASE BODY	1
1-5	157F.11.522	COLLAR	2
1-6	157F.10.470	NEUTRAL POSITION LAMP ASSY.	1
1-7	157F.11.405	WASHER 10.2X18X1.3	1
1-8	157F.03.006	SMALL LEFT COVER	1
1-9	157F.12.107	O-RING 108X2	1
1-10	157F.02.603	PIN	1
1-11	157F.12.115	O-RING 6X1.8	2
1-12	152.12.101	OIL SEAL 19.8X30X5	1
1-13	GB/T16674 M6X18	BOLT M6X18	12
1-14	157F.11.517	DOWEL PIN 10X14	2
1-15	152.11.205	DRAIN PLUG M12X1.5	1
1-16	GB97.1 12	WASHER 12	1
1-17	157F.11.521	COLLAR	1
1-18	152.02.601	CHAIN PULL ROD	1
1-19	152.11.515	DOWEL PIN 8X14	2
1-20	152.11.204	DOUBLE-END BOLT M8X195.5	2
1-21	152.11.203	DOUBLE-END BOLT M8X187.5	2
1-22	GB97.2 8	WASHER 8	4

1-23	GB6177 M8	NUT M8	4
1-24	GB/T16674 M6X50	BOLT M6X50	2
1-25	152.12.102	OIL SEAL 20X32X6	1
1-26	152.09.001	ENGINE OIL CLAPBOARD	1
1-27	GB/T16674 M6X12	BOLT M6X12	2

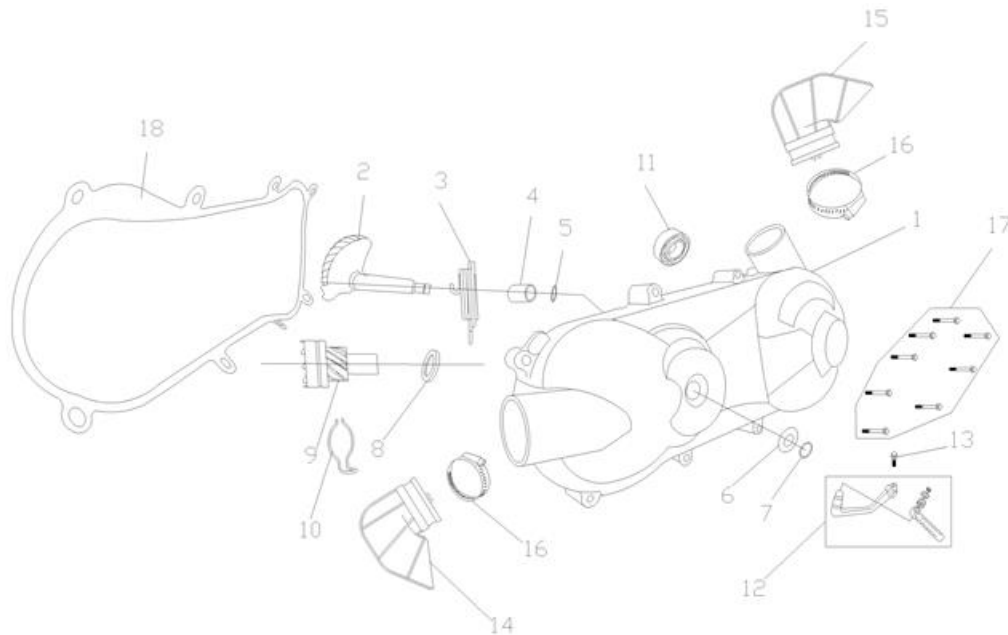
**FIG. 2 DRIVING GEAR COMP.**



<b>DRIVING GEAR COMP.</b>			
<b>REF NO.</b>	<b>PART NO.</b>	<b>DESCRIPTION</b>	<b>QTY</b>
2-1	157F.03.005	GEAR BOX COVER	1
2-2	157F.10.401	DRIVE SHAFT	1
2-3	157F.10.411	REVERSE SHAFT ASSY.	1
2-4	157F.10.420-SSA	SHIFTING SHAFT ASSY.	1
2-5	157F.10.402	OUTPUT SHAFT	1
2-6	157F.10.420-SDA	SHIFTING DRUM ASSY.	1
2-7	157F.10.403	SHIFTING FORK	1
2-8	157F.10.404	DECLUTCH SHIFT SHAFT	1
2-9	157F.10.440	CLUTCH SHIFT SHAFT ASSY.	1
2-10	157F.12.305	GEAR BOX COVER GASKET	1
2-11	157F.12.113	GEAR BOX AIR PIPE	1
2-12	157F.11.523	GEAR BOX AIR NOZZLE	1
2-13	GB/T308 Φ9.5	STEEL BALL Φ9.5	1
2-14	157F.10.410	SHIFTING DRUM POSITIONING SPRING	1
2-15	157F.11.407	WASHER 14.2X22X1.3	1
2-16	157F.10.409	SHIFTING DRUM POSITIONING BOLT	1
2-17	157F.11.524	CASE DRAIN NOZZLE	1
2-18	152.11.205	DRAIN PLUG M12X1.5	2
2-19	GB97.1 12	WASHER 12	2

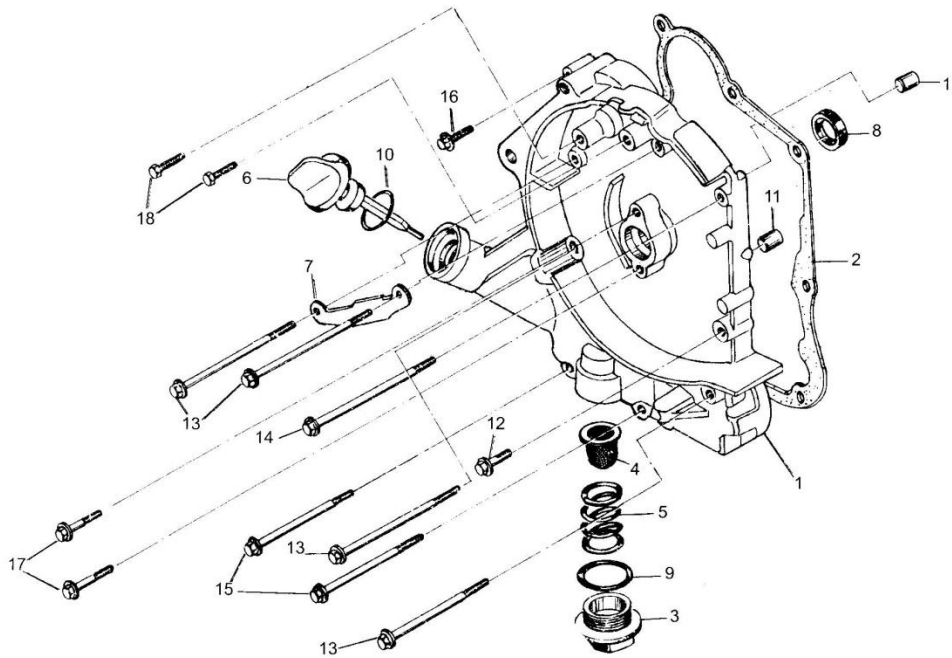
2-20	GB/T16674 M6X12	BOLT M6X12	1
2-21	157F.11.408	WASHER 6	1
2-22	157F.11.517	DOWEL PIN 10X14	2
2-23	157F.10.427	ADJUST WASHER 15	1
2-24	GB/T276 6202	BEARING 6202	1
2-25	GB/T276 6203	BEARING 6203	1
2-26	GB/T276 6204	BEARING 6204	2
2-27	GB/T894.1 $\Phi$ 20	SNAP RING $\Phi$ 20	1
2-28	GB/T276 6302	BEARING 6302	1
2-29	GB/T5801 RNA4905	NEEDLE ROLLER BEARING RNA4905	1
2-30	157F.12.114	DAMPING BUSHING	2
2-31	157F.12.103	OIL SEAL 30X40X6	1
2-32	GB/T276 6205-2RZ	BEARING 6205-2RZ	1
2-33	157F.10.437	ADJUST WASHER 25	1
2-34	GB/T894.1 $\Phi$ 25	SNAP RING $\Phi$ 25	1
2-35	GB/T893.1 $\Phi$ 52	SNAP RING $\Phi$ 52	1
2-36	157F.10.480	DRIVE SPROCKET	1
2-37	157F.10.481	SPROCKET LOCKING PLATE	1
2-38	GB/T16674 M6X12	BOLT M6X12	2
2-39	157F.11.503	CABLE CLAMP	1
2-40	GB5789 M6X40	BOLT M6X40	10

**FIG. 3 SIDE COVER COMP.**



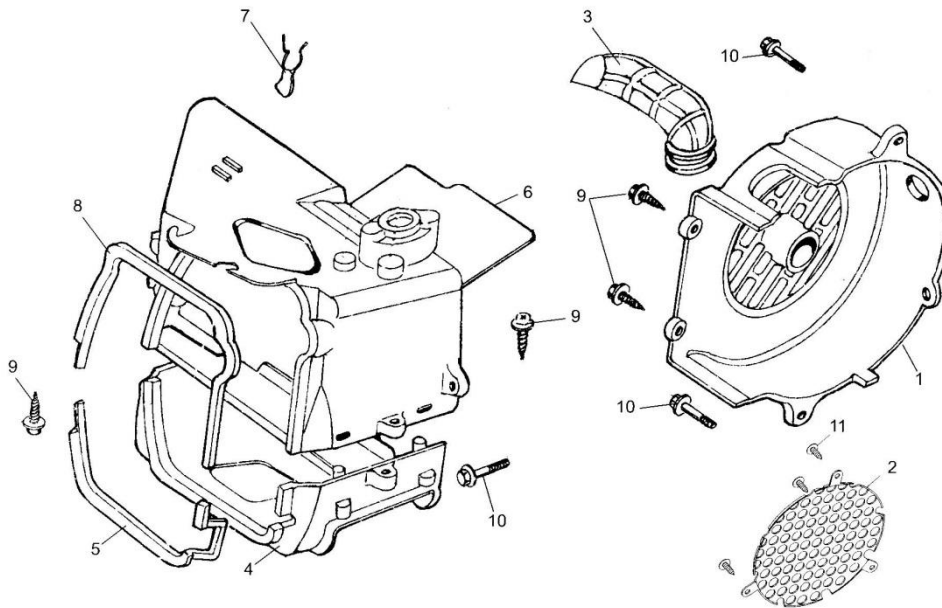
<b>SIDE COVER COMP.</b>			
<b>REF NO.</b>	<b>PART NO.</b>	<b>DESCRIPTION</b>	<b>QTY</b>
3-1	157F.03.003	LEFT CRANKCASE COVER	1
3-2	157F.06.300	STARTING SHAFT ASSY.	1
3-3	139.06.101	STARTING RETURN SPRING	1
3-4	157F.06.002	STARTING SHAFT BUSHING	1
3-5	157F.12.117	O-RING 13.8X2.3	1
3-6	139.11.403	WASHER	1
3-7	GB/T894.1 $\Phi$ 14	SNAP RING $\Phi$ 14	1
3-8	139.11.404	WASHER $\Phi$ 10	1
3-9	157F.06.400	STARTING DRIVEN GEAR ASSY.	1
3-10	139.06.103	FRICTION SPRING	1
3-11	GB/T276 6200-2RZ	BEARING 6200-2RZ	1
3-12	157F.06.200A	STARTING FOOT BAR	1
3-13	GB5789 M6X25	BOLT M6X25	1
3-14	157F.12.121	ASPIRATION CHANNEL A	1
3-15	157F.12.122	ASPIRATION CHANNEL B	1
3-16	157F.11.601	ASPIRATION CHANNEL CLIP	2
3-17	GB/T16674 M6X40	BOLT M6X40	8
3-18	157F.12.302	LEFT CRANKCASE COVER GASKET	1

**FIG. 4 RIGHT COVER COMP.**



<b>RIGHT COVER COMP.</b>			
<b>REF NO.</b>	<b>PART NO.</b>	<b>DESCRIPTION</b>	<b>QTY</b>
4-1	157F.03.004	RIGHT CASE COVER	1
4-2	152.12.303	RIGHT CASE COVER GASKET	1
4-3	152.09.002	OIL SCREEN SCREW PLUG	1
4-4	152.09.003-OS	OIL SCREEN	1
4-5	152.09.004	OIL SCREEN SPRING	1
4-6	152.12.201	OIL GAGE	1
4-7	152.11.508	MAGNETO WIRE CLIP	1
4-8	152.12.101	OIL SEAL 19.8X30X5	1
4-9	152.12.110	O-RING 30.8	1
4-10	152.12.108	O-RING 18X3	1
4-11	152.11.515	DOWEL PIN 8X14	2
4-12	GB/T16674 M6X28	BOLT M6X28	1
4-13	GB/T16674 M6X95	BOLT M6X95	4
4-14	GB/T16674 M6X100	BOLT M6X100	1
4-15	GB/T16674 M6X110	BOLT M6X110	2
4-16	GB/T16674 M6X35	BOLT M6X35	1
4-17	GB/T16674 M6X25	BOLT M6X25	2
4-18	GB5783 M5X12	BOLT M5X12	2

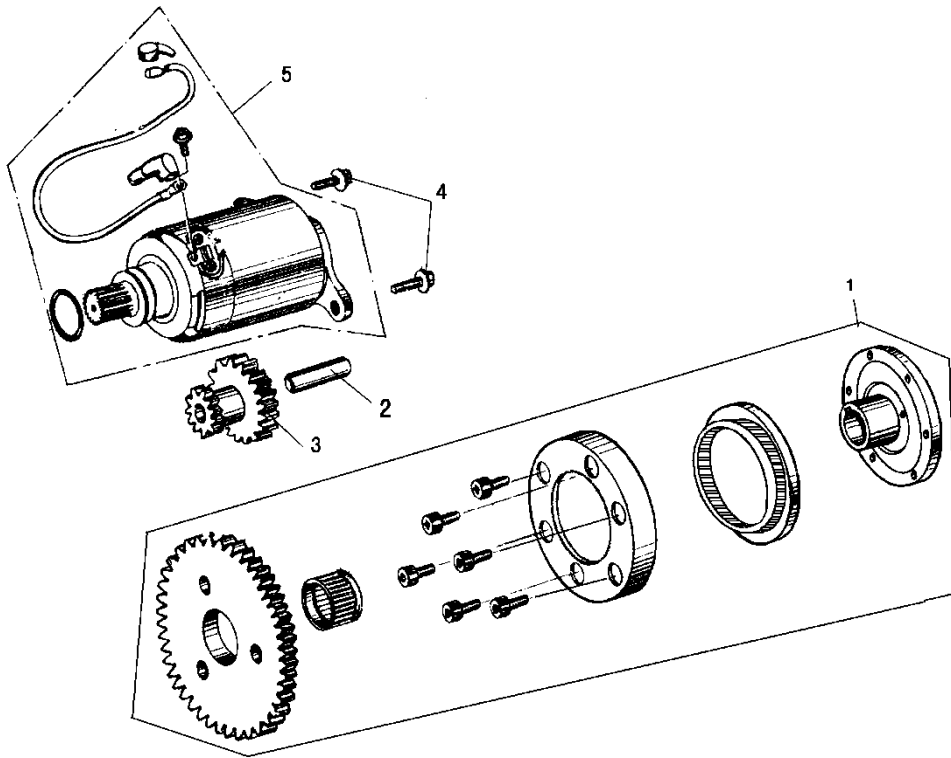
**FIG. 5 FAN / WIND GUIDE COVER**



<b>FAN / WIND GUIDE COVER</b>			
REF NO.	PART NO.	DESCRIPTION	QTY
5-1	152.05.002	FAN VOLUTE ASSY.	1
5-2	157A.12.305	FAN COVER CLAPBOARD	1
5-3	152.12.118	COOLING PIPE	1
5-4	152.05.004	WIND GUIDE COVER ASSY. LOWER	1
5-5	152.12.117	WIND GUIDE COVER ASSY. LOWER SEAL	1
5-6	152.05.003	WIND GUIDE COVER ASSY. UPPER	1
5-7	152.12.203	HIGH-VOLTAGE CABLE CLIP	1
5-8	152.12.116	WIND GUIDE COVER ASSY. UPPER SEAL	1
5-9	GB/T16824.2 ST4.8X16	TAPPING SCREW ST4.8X16	4
5-10	GB/T16674 M6X25	BOLT M6X25	3
5-11	GB845 ST3.8X11	TAPPING SCREW ST3.8X11	3

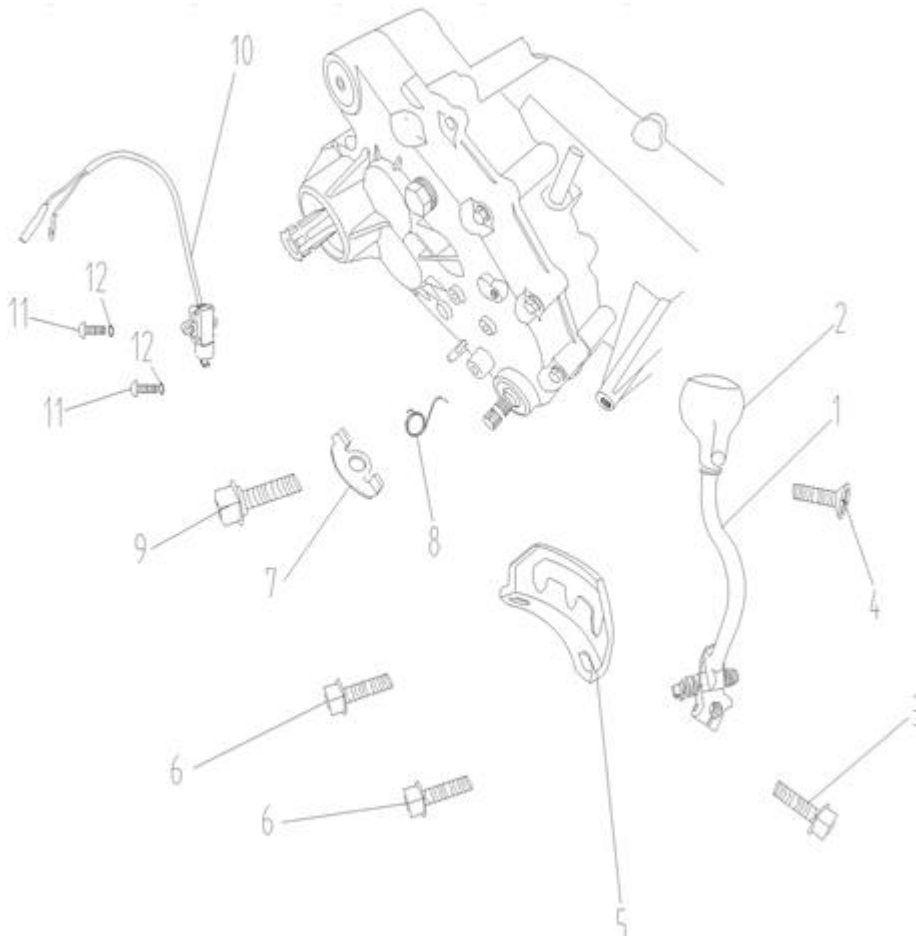


**FIG. 6 ELECTRIC START SYSTEM**



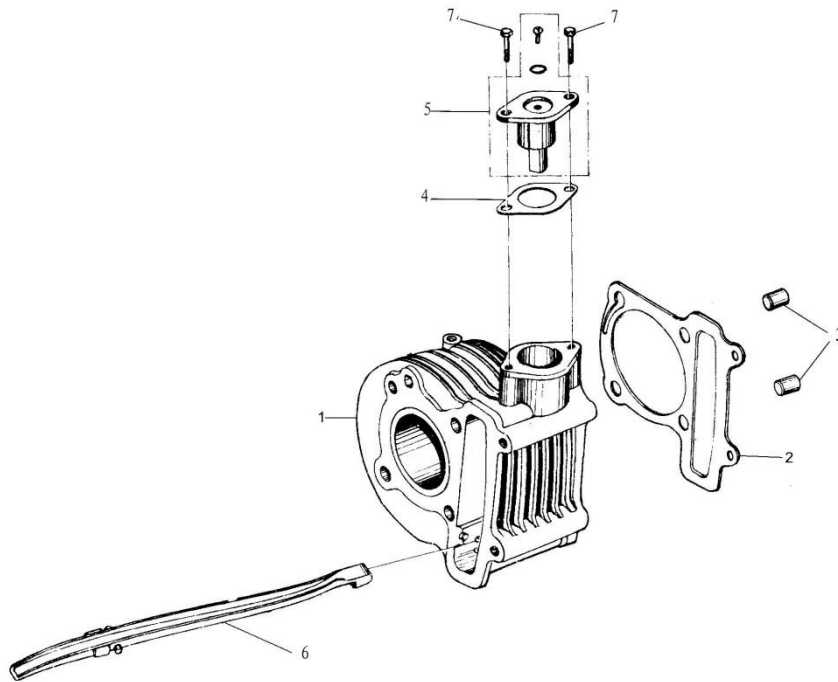
<b>ELECTRIC START SYSTEM</b>			
REF NO.	PART NO.	DESCRIPTION	QTY
6-1	152.06.100	OVERRUN CLUTCH	1
6-2	152.06.003	ELECTRIC STARTING GEAR SHAFT	1
6-3	152.06.002	STARTING GEAR	1
6-4	GB/T16674 M6X16	BOLT M6X16	2
6-5	152.07.500	STARTING MOTOR	1

**FIG. 7 SHIFTING CONTROL SYSTEM**



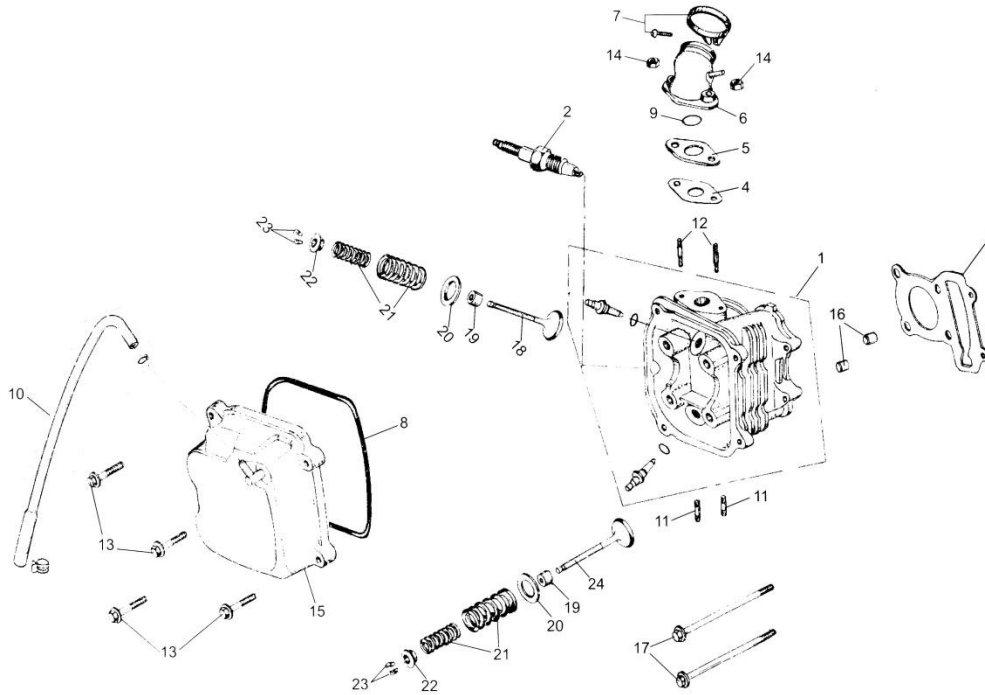
<b>SHIFTING CONTROL SYSTEM</b>			
REF NO.	PART NO.	DESCRIPTION	QTY
7-1	157F.10.450	SHIFTING BAR ASSY.	1
7-2	157F.10.455	HANDLE ASSY.	1
7-3	GB5789 M6X25	BOLT M6X25	1
7-4	GB/T819 M6X20	COUNTERSUNK HEAD SCREW M6X20	1
7-5	157F.10.405	SHIFT POSITIONING PLATE	1
7-6	GB5789 M6X12	BOLT M6X12	2
7-7	157F.10.406	GEARS BRIDGE PLATE	1
7-8	157F.10.407	TORSION SPRING	1
7-9	157F.10.408	BOSS BOLT	1
7-10	157F.10.460	REVERSE LAMP ASSY.	1
7-11	GB/T818 M5X16	CROSS RECESS HEAD SCREW M5X16	2
7-12	GB/T93 5 5	SPRING WASHER 5	2

**FIG. 9 CYLINDER COMP.**



<b>CYLINDER COMP.</b>			
<b>REF NO.</b>	<b>PART NO.</b>	<b>DESCRIPTION</b>	<b>QTY</b>
9-1	157.04.100	CYLINDER	1
9-2	152.12.304	CYLINDER GASKET	1
9-3	152.11.516	DOWEL PIN 10X16	2
9-4	152.09.003-CAS	CHAIN ADJUSTER SPACER	1
9-5	152.02.400	CHAIN ADJUSTER ASSY.	1
9-6	152.02.602	CHAIN GUILDER	1
9-7	GB/T16674 M6X20	BOLT M6X20	1

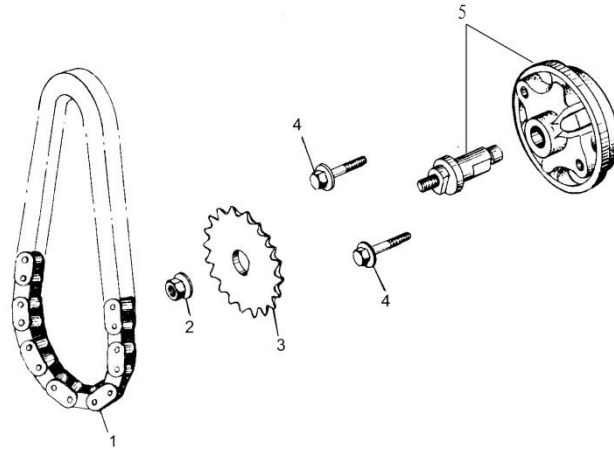
**FIG. 10 CYLINDER HEAD COMP.**



<b>CYLINDER HEAD COMP.</b>			
REF NO.	PART NO.	DESCRIPTION	QTY
10-1	157.04.200	CYLINDER HEAD	1
10-2	152.07.200	SPARK PLUG (C7HSA NGK)	1
10-3	157.04.401	CYLINDER HEAD GASKET	1
10-4	152.12.307	INSULATOR SPACER	1
10-5	152.08.201	CARBURETOR INSULATOR	1
10-6	152.08.200	INTAKE TUBE ASSY.	1
10-7	152.08.210	INTAKE TUBE CLAMP COMP.	1
10-8	152.12.111	CYLINDER HEAD COVER RUBBER GASKET	1
10-9	152.12.109	O-RING 27X2	1
10-10	152.12.112	CYLINDER HEAD BREATHER PIPE	1
10-11	152.11.201	DOUBLE-END BOLT M6X32	2
10-12	152.11.202	DOUBLE-END BOLT M6X63	2
10-13	GB/T16674 M6X25	BOLT M6X25	4
10-14	GB6177 M6	NUT M6	2
10-15	152.04.301	CYLINDER HEAD COVER	1
10-16	152.11.516	DOWEL PIN 10X16	2
10-17	GB/T16674 M6X100	BOLT M6X100	2
10-18	157.02.301	INTAKE VALVE	1

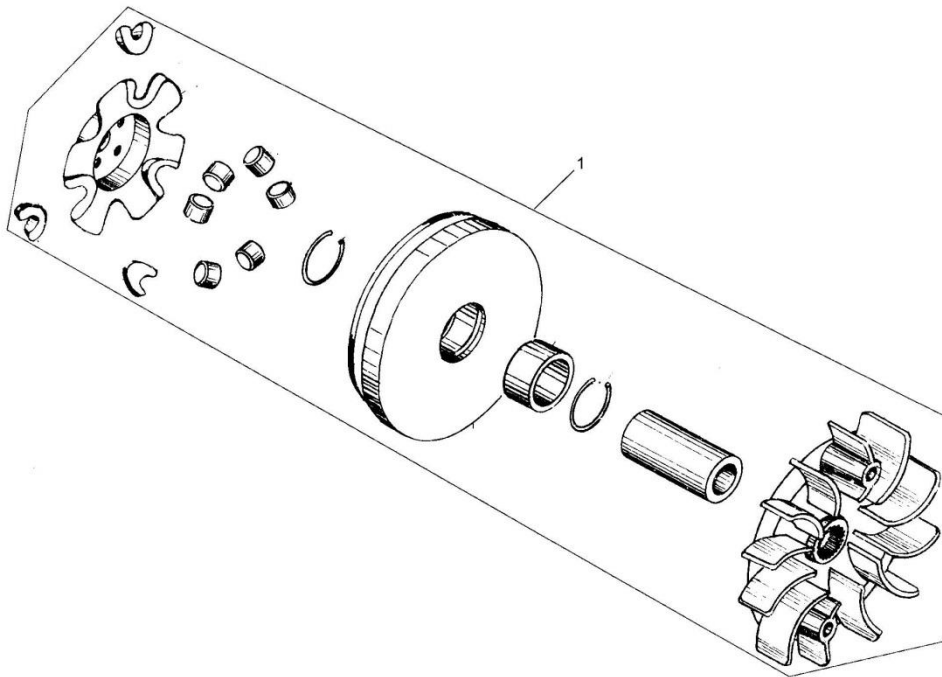
10-19	152.12.104	VALVE OIL SEAL	2
10-20	152.02.306	VALVE SPRING SEAT	2
10-21	152.02.303-304	VALVE SPRING	2
10-22	152.02.305	VALVE SPRING RETAINER	2
10-23	152.02.307	VALVE LOCKING CLAMP	4
10-24	157.02.302	EXHAUST VALVE	1

**FIG. 11 ENGINE OIL PUMP**



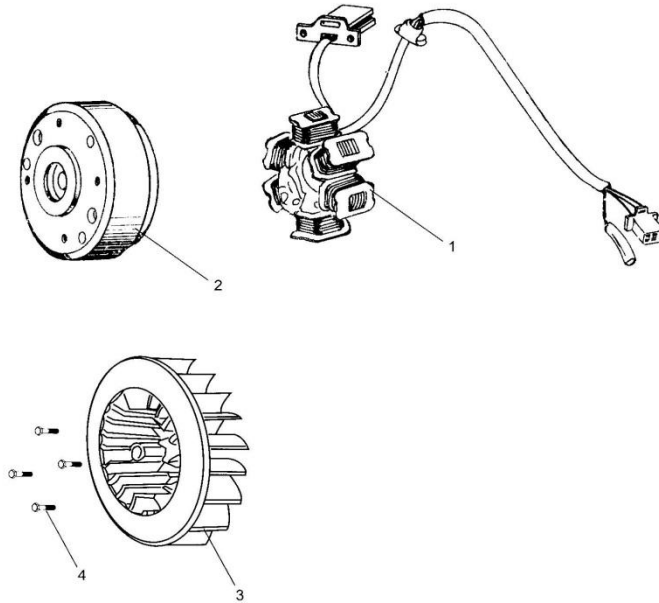
<b>ENGINE OIL PUMP</b>			
REF NO.	PART NO.	DESCRIPTION	QTY
11-1	152.09.200	OIL PUMP CHAIN	1
11-2	GB6177 M6	NUT M6	1
11-3	152.09.005	OIL PUMP SPROCKET	1
11-4	GB/T16674 M6X25	BOLT M6X25	2
11-5	152.09.100	OIL PUMP ASSY.	1

**FIG. 12 DRIVING WHEEL COMP.**



<b>DRIVING WHEEL COMP.</b>			
REF NO.	PART NO.	DESCRIPTION	QTY
12-1	157F.10.100	DRIVING WHEEL COMP.	1

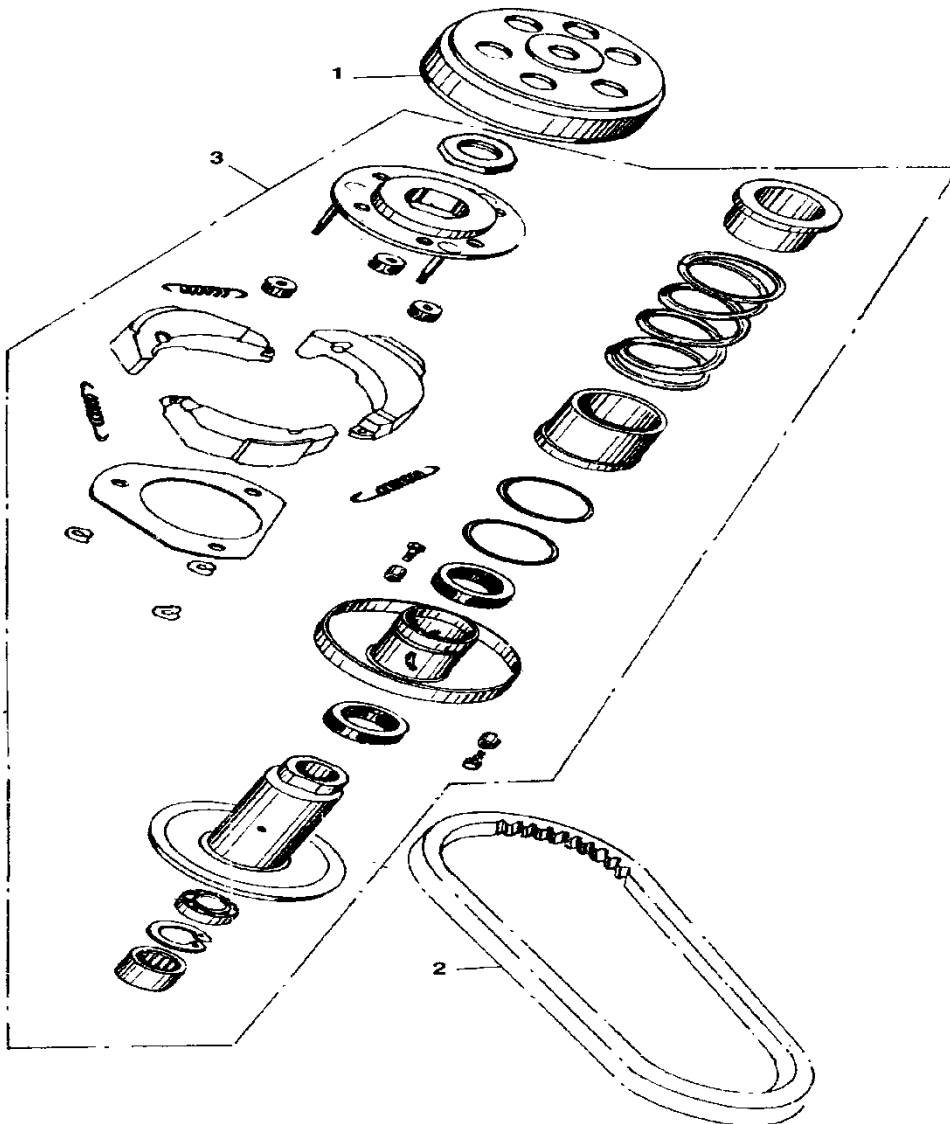
**FIG. 13 MAGNETOR**



<b>MAGNETOR</b>			
REF NO.	PART NO.	DESCRIPTION	QTY
13-1	152.07.102	MAGNETO STATOR ASSY.	1
13-2	152.07.101	MAGNETO FLYING WHEEL ASSY.	1
13-3	152.05.001	FAN IMPELLER	1
13-4	GB/T16674 M6X18	BOLT M6X18	4

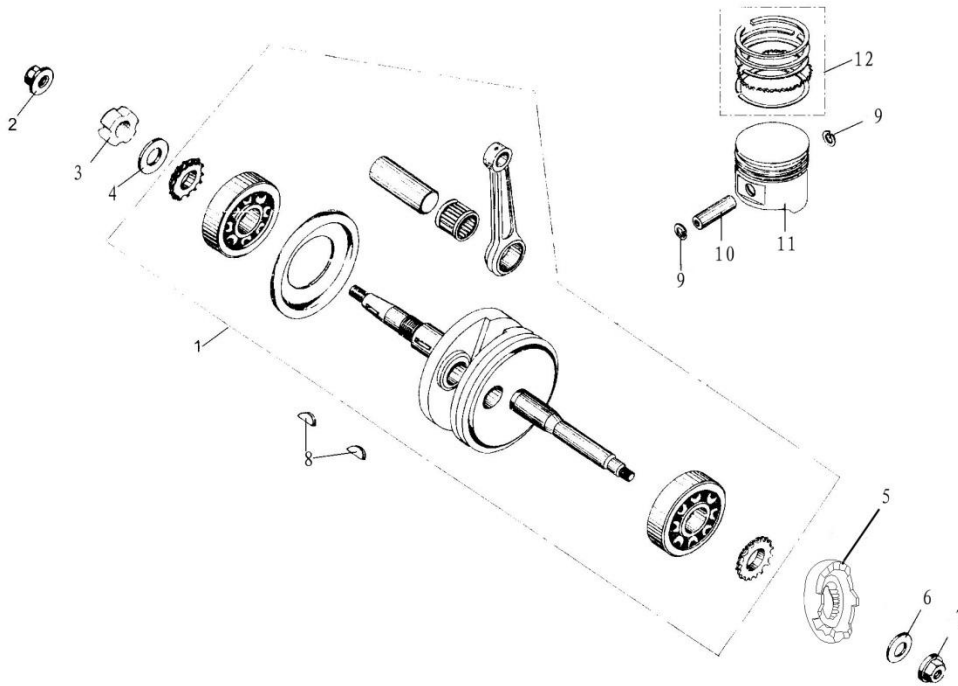


**FIG. 14 DRIVEN WHEEL COMP.**



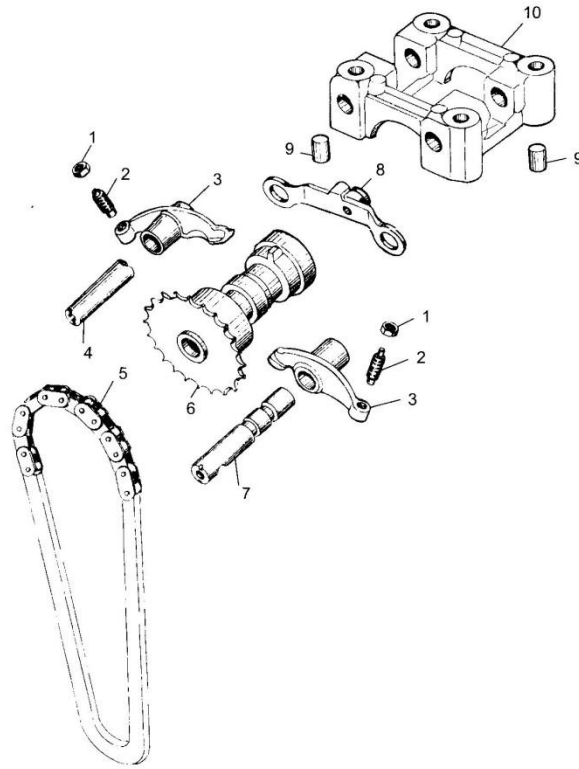
<b>DRIVEN WHEEL COMP.</b>			
<b>REF NO.</b>	<b>PART NO.</b>	<b>DESCRIPTION</b>	<b>QTY</b>
14-1	152.10.210	CLUTCH COAT ASSY.	1
14-2	152.10.300	BELT	1
14-3	152.10.200	DRIVEN WHEEL COMP.	1

**FIG. 15 CRANKSHAFT / PISTON COMP.**



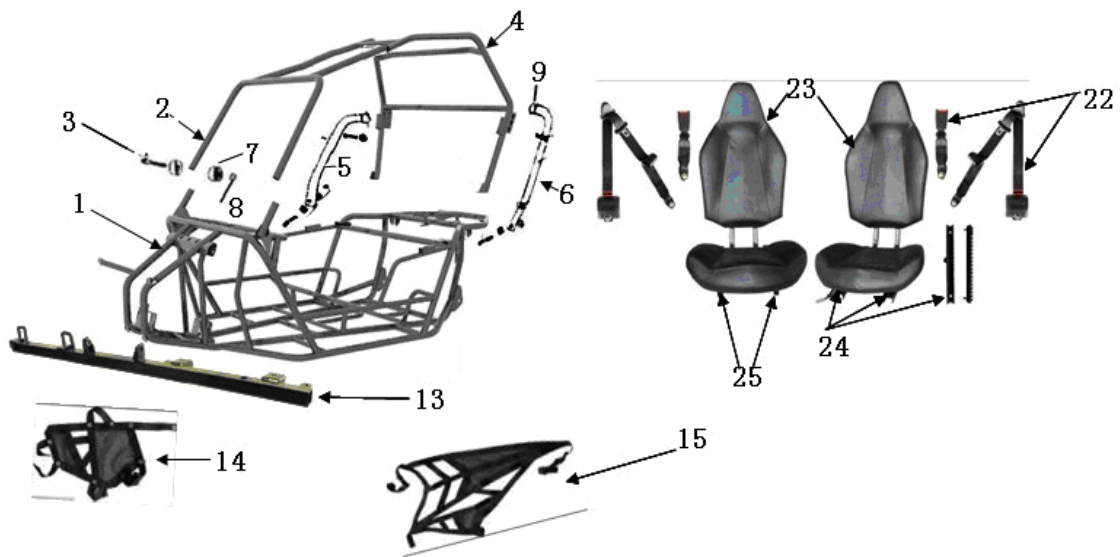
<b>CRANKSHAFT / PISTON COMP.</b>			
REF NO.	PART NO.	DESCRIPTION	QTY
15-1	157F.01.100	CRANKSHAFT	1
15-2	GB6187 M12X1.25	SELF-LOCKING NUT M12X1.25	1
15-3	152.11.301	LOCKING NUT M22X1	1
15-4	152.11.402	WASHER 22X31X2.5	1
15-5	157F.06.001	RATCHET WHEEL	1
15-6	157F.11.403	WASHER 15.2X25X2.3	1
15-7	GB6177 M12X1.25X11	NUT M12X1.25X11	1
15-8	152.11.101	WOODRUFF KEY 4X14	2
15-9	152.01.307	PISTON PING SNAP RING	2
15-10	157.01.306	PISTON PING	1
15-11	157.01.301	PISTON	1
15-12	157.01.302-305	PISTON RING	1

**FIG. 16 TIMING SYSTEM**



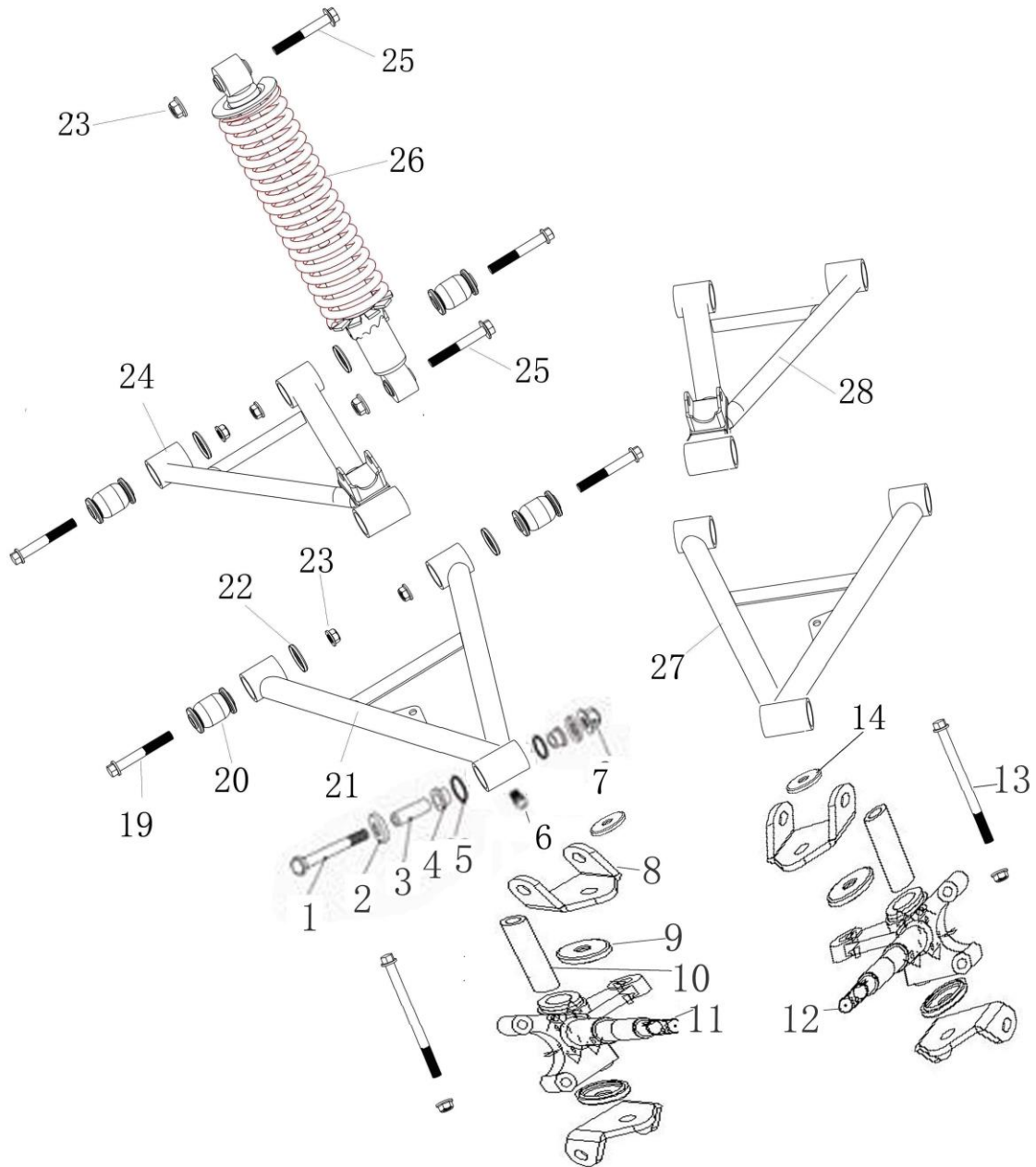
<b>TIMING SYSTEM</b>			
REF NO.	PART NO.	DESCRIPTION	QTY
16-1	152.02.106	VALVE ADJUSTING NUT	2
16-2	152.02.105	VALVE LASH ADJUSTING SCREW	2
16-3	152.02.102	VALVE ROCKET	2
16-4	152.02.104	EXHAUST VALVE ROCKER SHAFT	1
16-5	152.02.500	CAMSHAFT DRIVING CHAIN	1
16-6	152.02.200	CAMSHAFT COMP.	1
16-7	152.02.103	INTAKE VALVE ROCKER SHAFT	1
16-8	152.02.107	STOPPING PLATE	1
16-9	152.11.516	DOWEL PIN 10X16	2
16-10	152.02.101	CAMSHAFT FIXING BRACKET	1

**FIG 17. FRAME/SEAT**



<b>FRAME AND SEAT</b>			
<b>REF NO.</b>	<b>PART NO.</b>	<b>DESCRIPTION</b>	<b>QTY</b>
17-1	19-0801010	FRAME	1
17-2	19-0801020	ROLL CAGE	2
17-3	19-0801021	9.908.055N Bolt	12
17-4	19-0801030	BAR	2
17-5	19-0801040	RAILING BAR RIGHT	1
17-6	19-0801050	RAILING BAR LEFT	1
17-7	19-0801070	R-WASHER	12
17-8	19-0100710	LOCKING FLANGE NUT M8	8
17-9	19-0100502	TUBE SEAT	6
17-13	58010150U	SEAT SUPPORT SHELF	1
17-22	19-0800401	SAFETY BELT	1
17-23	19-0800301	SEAT	1
17-24	19-0800302	DRIVER SEAT SLIDER	1
17-25	19-0800303	PASSENGER SEAT SLIDER	1

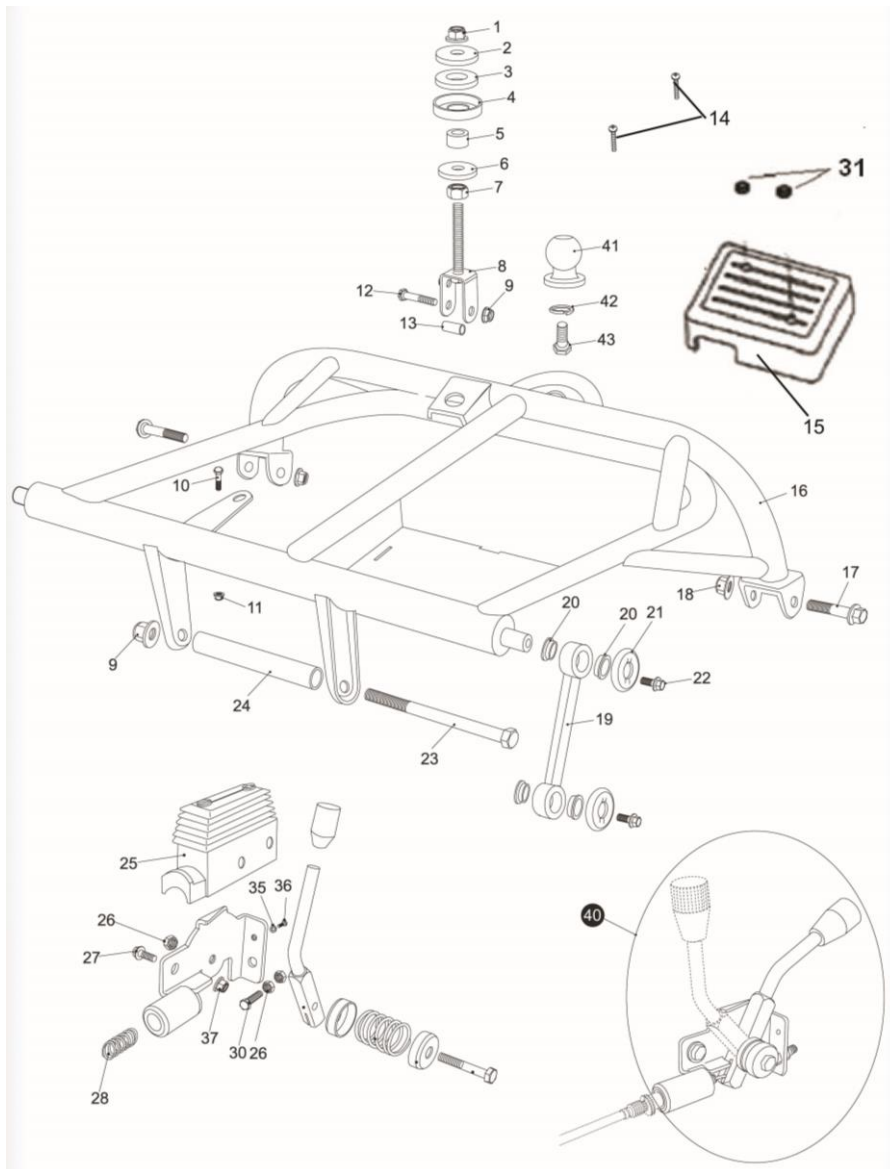
**FIG.18 SUSPENSION ARM ASSEMBLY**



SUSPENSION ARM ASSEMBLY			
REF NO.	PART NO.	DESCRIPTION	QTY
18-1	57891008012505	BOLT M10X1.25X80	4
18-2	8.020.034	LOWER SUSPENSION ARM DUST CAP	4
18-3	58701-150U	LOWER SUSPENSION ARM COLLAR	8

18-4	7.010.002	LOWER SUSPENSION ARM BUSHING	8
18-5	9.040.001	O-RING $\phi$ 21.2X2.65	8
18-6	54006400N000	LUBRICATING NIPPLE	4
18-7	GB6187 M10X1.25	NUT GB6187 M10 $\times$ 1.25	12
18-8	44001-150U	FRONT SHOCK MOUNT PLATE	4
18-9	54300N	CUSHION	4
18-10	54004N	HUB COLLAR	2
18-11	44210-150U	LEFT FRONT WHEEL SHAFT ASSY.	1
18-12	44220-150U	RIGHT FRONT WHEEL SHAFT ASSY.	1
18-13	57891011012505	BOLT M10X1.25X110	2
18-14	44003-150U	FRONT SHOCK MOUNT ADJUSTING PLATE	2
18-15	57891007512505	BOLT M10X1.25X75	8
18-16	58720N	CUSHION BUSH	8
18-17	58710-150U	FRONT LOWER SUSPENSION ARM ASSY.L.	1
18-18	58730-150U	FRONT UPPER SUSPENSION ARM ASSY.L.	1
18-19	57891004512505	BOLT M10X1.25X45	2
18-20	6.000.325	REAR SHOCK ASSY.	2
18-21	58750N	FRONT LOWER SUSPENSION ARM ASSY.R.	1
18-22	58760-150U	FRONT UPPER SUSPENSION ARM ASSY.R.	1
18-23	57891005512505	BOLT M10X1.25X55	2

**FIG.19 REAR SWING ARM ASSY. UPPER**

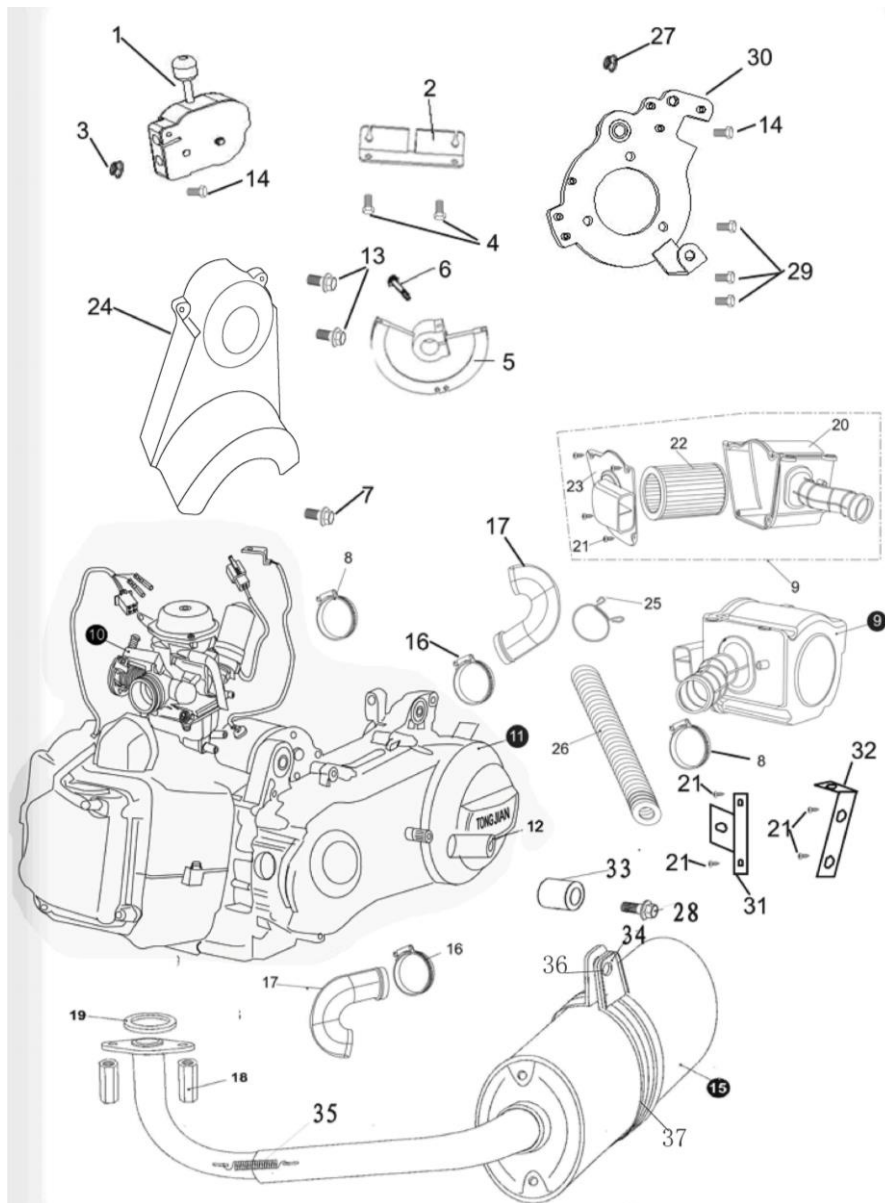


REAR SWING ARM ASSY. UPPER			
REF NO.	PART NO.	DESCRIPTION	QTY
19-1	61871200012505	LOCKING FLANGE NUT M12	1
19-2	8.010.042	ENGINE MOUNT LINK WASHER	1
19-3	7.020.001	ENGINE MOUNT LINK CUSHION	1
19-4	8.020.045	ENGINE MOUNT LINK SPACER	1
19-5	8.010.041	ENGINE MOUNT LINK COLLAR	1
19-6	8.010.042	FLAT WASHER 12	1
19-7	61701200012505	NUT M12	1
19-8	6.000.026	ENGINE MOUNT BOLT PLATE	1
19-9	61871000012505	LOCKING FLANGE NUT M10	1
19-10	57890601610005	BOLT M6X16	1

19-11	61870600010005	LOCKING FLANGE NUT. M6	1
19-12	57851004512505	BOLT M10X1.25X45	1
19-13	8.010.076	ENGINE MOUNT BOLT PLATE COLLAR	1
19-14	81800606010004	PAN SCREW M6X60	2
19-31	7.010.006	SCREW CAP	2
19-15	7.010.029	BATTERY BOX COVER	1
19-16	2.000.029	REAR SWING ARM ASSY. UPPER	1
19-17	57891206012505	FLANGE BOLT M12X1.25X60	2
19-18	61871200012505	LOCKING FLANGE NUT M12	2
19-19	58310-150U	SWING ARM DOG BONE	2
19-20	7.010.002	CON'ROD BUSH	8
19-21	8.020.013	CON'ROD SPACER	4
19-22	57870801212505	BOLT M8X12	4
19-23	57871019012505	BOLT M10X1.25X190	1
19-24	8.010.025	ENGINE MOUNT COLLAR	1
19-40	6.000.042	PARKING BRAKE LEVER ASSY.	1
19-25	7.020.024	REVERSE LEVER COVER	1
19-27	57870802012505	FLANGE BOLT M8X1.25X20	1
19-28	8.040.004	CABLE SPRING	1
19-30	57870802012505	FLANGE BOLT M8X1.25X20	1
19-35	9.300.005	FLAT WASHER 5	1
19-36	90746501610005	PAN SCREW M5X16	1
19-37	61870800012505	LOCKING FLANGE NUT M8	2
19-41	8.010.084	TOW BALL	1
19-42	93001600000003	LOCKING WASHER 16	1
19-43	57831602520003	BOLT M16X2X25	1



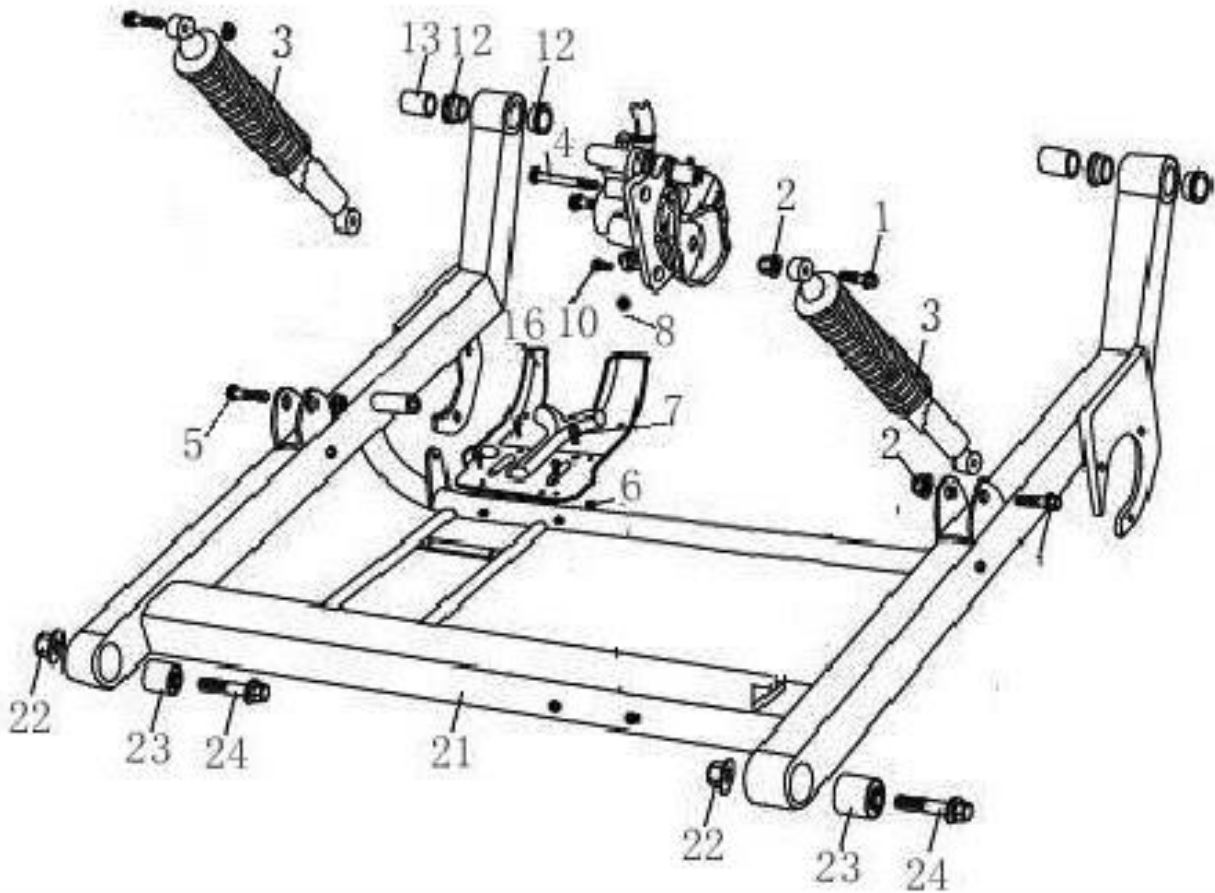
**FIG. 20 ENGING/MUFLER/AIR CLEANER**



ENGING/MUFLER/AIR CLEANER			
REF NO.	PART NO.	DESCRIPTION	QTY
20-1	40700-150U	150U SHIFT HOISE ASSY	1
20-2	40001-300GK	REVERSE CABLE FIXED PLATE	1
20-3	61870800012505	LOCKING NUT M8	1
20-4	57890601210005	BOLT M6X12	2
20-5	40002-300GK	SHIFT DISC	1
20-6	578306025100	BOLT M6x25	1
20-7	578908030125	BOLT M8X30	1
20-8	8.020.056	AIR CLEANER CLAMP	2
20-9	4.000.018	AIR CLEANER ASSY.	1
20-10	PD24J	CARBURETOR	1
20-11	2.000.009-150XRS	150 ENGINE	1

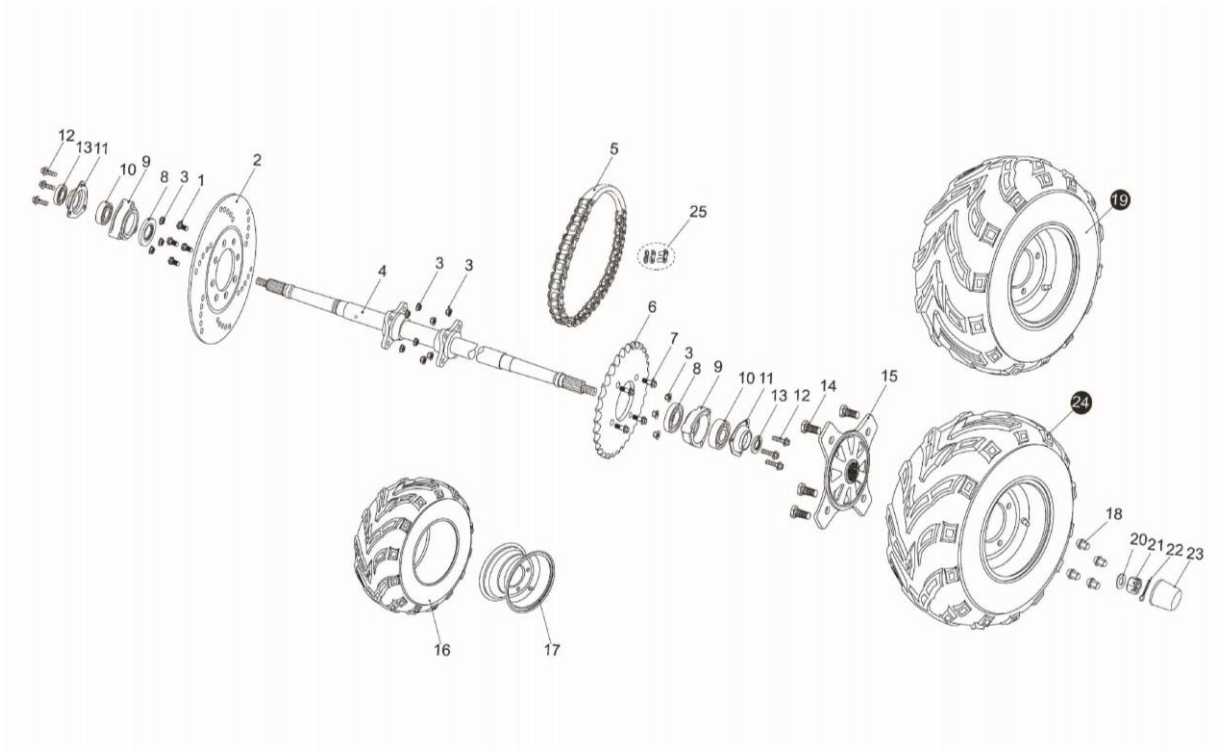
20-12	8.030.037-150XRS	MUFFLER RACK SUPPORT	1
20-13	57890603010005	BOLT M6X30	2
20-14	57870802012505	BOLT M8X20	1
20-15	6.000.229-MCE	MUFFLER COMP.	1
20-16	8.020.055-150XRS	BOLT CLAMP	2
20-17	6.000.162-150XRS	SIDE CASE BOLT	2
20-18	9.040.027	MUFFLER JOINT NUT M6	2
20-19	9.040.005	EX. PIPE GASKET	1
20-20	7.010.047	AIR CLEANER CASE COMP.	1
20-21	9.805.003	SCREW ST5X20	9
20-22	6.000.151	AIR FILTER ELEMENT	1
20-23	7.010.048	AIR FILTER COVER	1
20-24	7.010.133-150XRS	REAR CHAIN PROTECTOR	1
20-25	7.020.054	AIR CLEANER CLIP	1
20-26	7.010.057	AIR CLEANER DUCT	1
20-27	6177080012505	NUT M8	1
20-28	57870804512505	BOLT M8X45	1
20-29	57830801612505	BOLT M18X16	3
20-30	10111-300GK	ENGINE MOUNT PLATE	1
20-31	49002-150	FRONT AIR CLEANER MOUNT PLATE	1
20-32	49003-150	REAR AIR CLEANER MOUNT PLATE	1
20-34	8.020.166	EMBRACE HOOP FOR MUFFLER	1
20-35	58235400N000	MUFFLER SPRING	2
20-36	96001000000005	WASHER GB96 10	1
30-37	47006150G000	MUFFLER RUBBER CUSHION	1

**FIG 21 REAR SWING ARM**



REAR SWING ARM ASSY			
REF NO.	PART NO.	DESCRIPTION	QTY
21-1	57891004012505	FLANGE BOLT M10X1.25X40	4
21-2	61871000012505	LOCKING FLANGE NUT M10	4
21-3	6.000.006	CUSHION ASSY. RR	2
21-4	57890810012505	BOLT STRAP M8X1.25X100	1
21-5	9.108.045	FLANGE BOLT M8X1.25X45	2
21-6	57890601210005	FLANGE BOLT M6X12	4
21-7	617706000010005	LOCKING NUT M6	4
21-8	930008000000005	SPRING WAHSER 8	2
21-10	57890801212505	BOLT STRAP M8X1.25X12	1
21-12	7010006150G000	SWING ARM BUSH.	4
21-13	8.010.028	SWING ARM COLLAR.	2
21-16	7.010.032-150XRS	CHAIN. DISC GUARD.	1
21-21	2.000.042	RR, LOWER SWING ARM COMP.	1
21-22	9.220.012	LOCKING FLANGE NUT M12	2
21-23	7.020.008	SWING ARM CUSHION BUSHING	2
21-24	57891206012505	BOLT M12X1.25X60	2

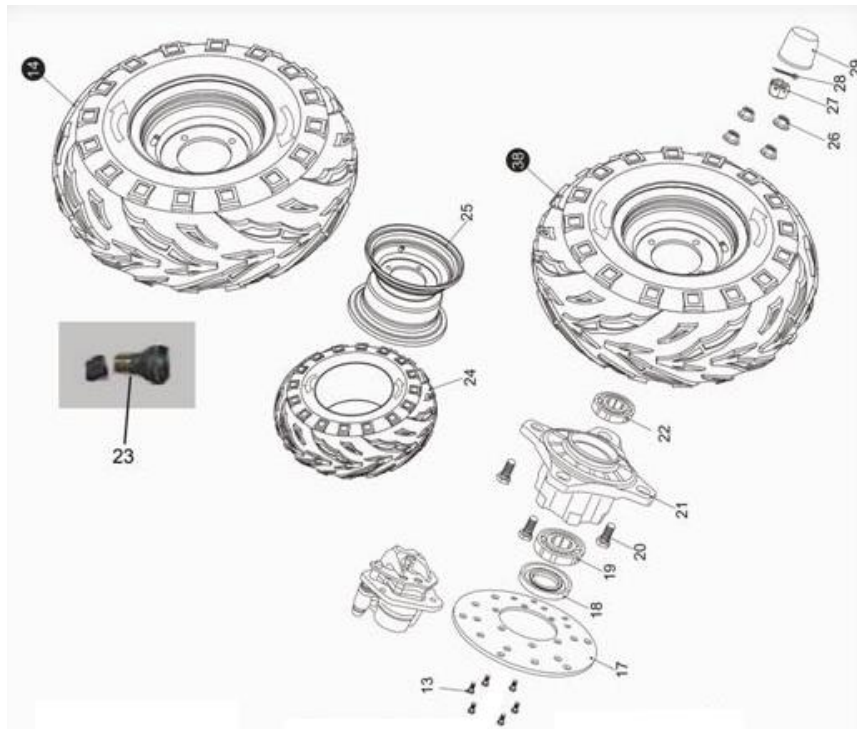
**FIG. 22 REAR HOUSING**



<b>REAR HOUSING</b>			
REF NO.	PART NO.	DESCRIPTION	QTY
22-1	57870802212505	BOLT-WASHER M8X1.25X22	4
22-2	8.010.053	RR. BRAKE DISC	1
22-3	61870800012505	LOCKING FLANGE NUT M8	14
22-4	8.010.057-150XRS	REAR AXLE	1
22-5	9.070.002-150XRS	DRIVE CHAIN	1
22-6	8.010.077	REAR SPROCKET	1
22-7	57870802612505	BOLT-WASHER M8X1.25X26	4
22-8	9.040.006	DUST SEAL 50X34-7	2
22-9	8.030.008	RR. AXLE BRG HOUSING COMP	2
22-10	62062RS0000000	BEARING 6206	2
22-11	8.020.028	BEARING BASE	2
22-12	57870804012505	BOLT-WASHER M8X1.25X40	6
22-13	9.040.007	DUST SEAL 42X30-7	2
22-14	9.710.031	TIRE BOLT. M10X1.25X31	8
22-15	8.010.056-150XRS	REAR AXLE HUB.	2
22-19	6.000.052-GT	REAR WHEEL ASSY. R	1
22-16	7.020.035-GT	TIRE. RR 21X10-10	2
22-17	6.000.105	RIM. RR	2
22-18	61871000012505	LUG NUT CAP M10	8
22-20	97001600000005	RR. WHEEL SPACER. φ16	2

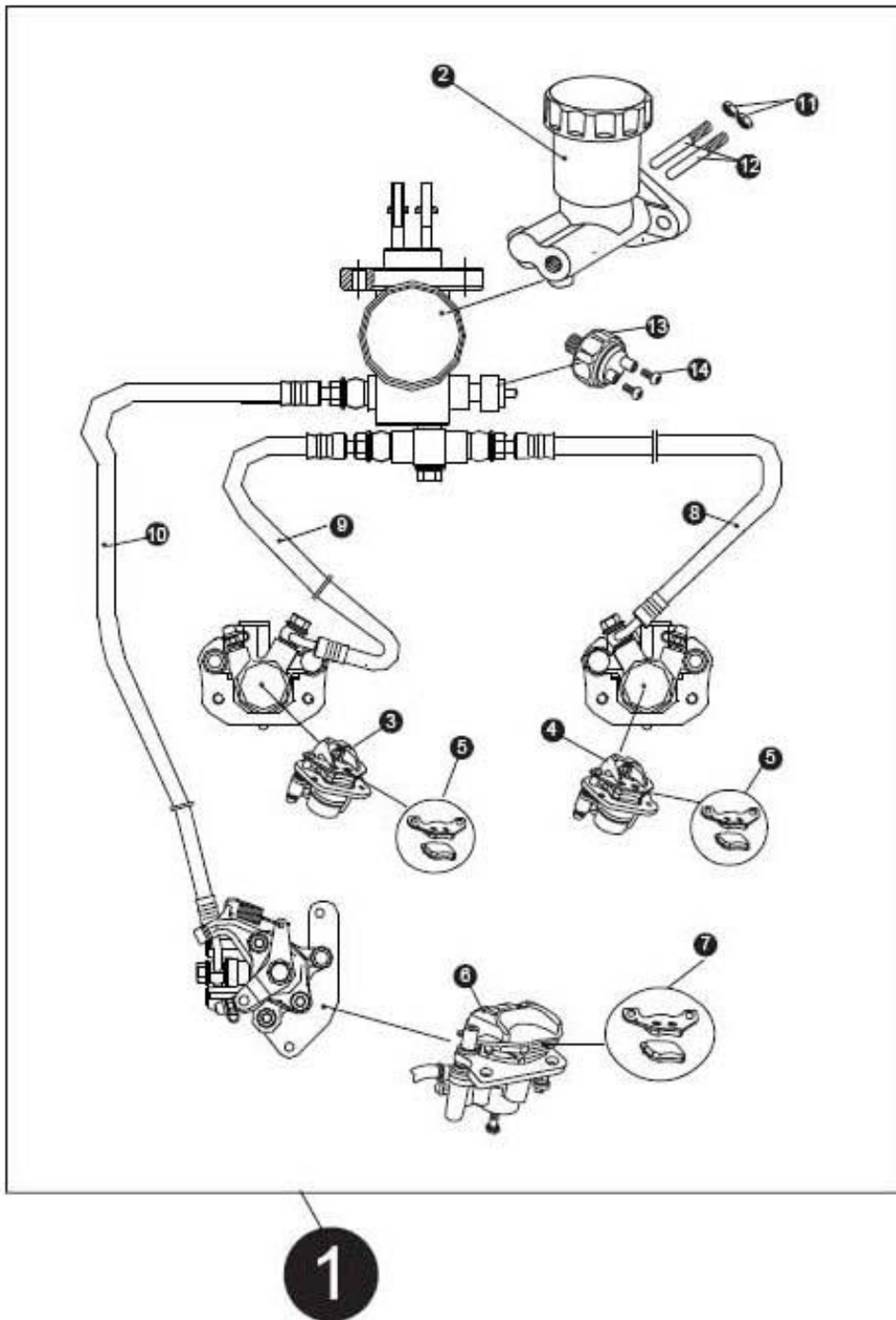
22-21	94571600015005	CASTLE NUT.M16	2
22-22	GB914004000002	COTTER PIN $\phi$ 4X40	2
22-23	7.020.039	HUB COVER	2
22-24	6.000.383	REAR WHEEL ASSY. L	1
22-25	6.000.149	CHAIN MASTER LINK	1
22-26	7.190.018	TIRE VALVE	2

**FIG. 23 FRONT WHEEL SYSTEM**



<b>FRONT WHEEL SYSTEM</b>			
<b>REF NO.</b>	<b>PART NO.</b>	<b>DESCRIPTION</b>	<b>QTY</b>
23-13	57830601610005	BOLT STRAP M6X16	12
23-14	6.000.097-GT	FR. WHEEL ASSY. R.	1
23-17	8.010.054	FR. DISC. BRAKE	2
23-18	YF047002500700	DUST SEAL 47*25-7	2
23-19	62042RS0000000	BEARING 6204	2
23-20	9.710.031	TIRE BOLT. M10X1.25X31	8
23-21	8.010.085-150XRS	FR. WHEEL HUB.	2
23-22	62022RS0000000	BEARING 6202-Z	2
23-26	61871000012505	LOCKING FLANGE NUT M10	8
23-27	94571400015005	CASTLE NUT M14	2
23-28	GB913003000002	COTTER PIN 3X30	2
23-29	7.020.039	HUB COVER	2
23-38	6.000.093-GT	FR. WHEEL ASSY. L.	1

**FIG. 24 BRAKE ASSY.**

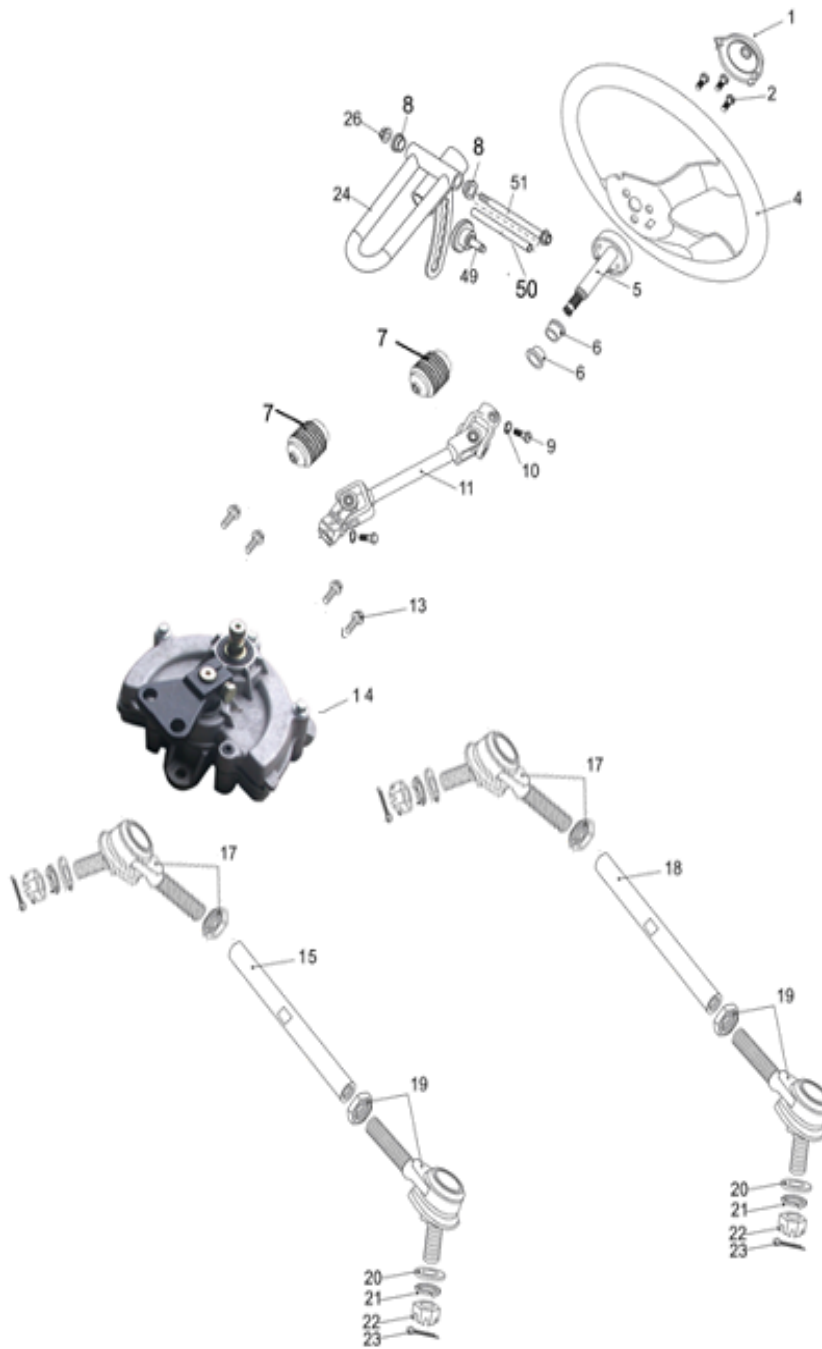


<b>BRAKE ASSY.</b>			
REF NO.	PART NO.	DESCRIPTION	QTY
24-1	45000-150U	BRAKE ASSY	1
24-2	45110N	BRAKE MASTER CYLINDER	1
24-3	6.000.095	FRONT BRAKE CALIPER R.	1
24-4	6.000.028-150	FRONT BRAKE CALIPER L.	1
24-5	7.020.016	FRONT BRAKE PAD SET	2

24-6	6.000.229	BRAKE CALIPER ASSY. RR	1
24-7	7.020.022	REAR BRAKE PAD SET	1
24-8	6.000.089-150U	LEFT FRONT BRAKE HOSE	1
24-9	6.000.090-150U	RITHT FRONT BRAKE HOSE	1
24-10	6.000.091-150U	REAR BRAKE HOSE	1
24-11	8.010.081	BRAKE PIN SPINDLE	1
24-12	617008000125	NUT M8	1
24-13	6.000.063-150U	BRAKE LIGHT SWITCH	1



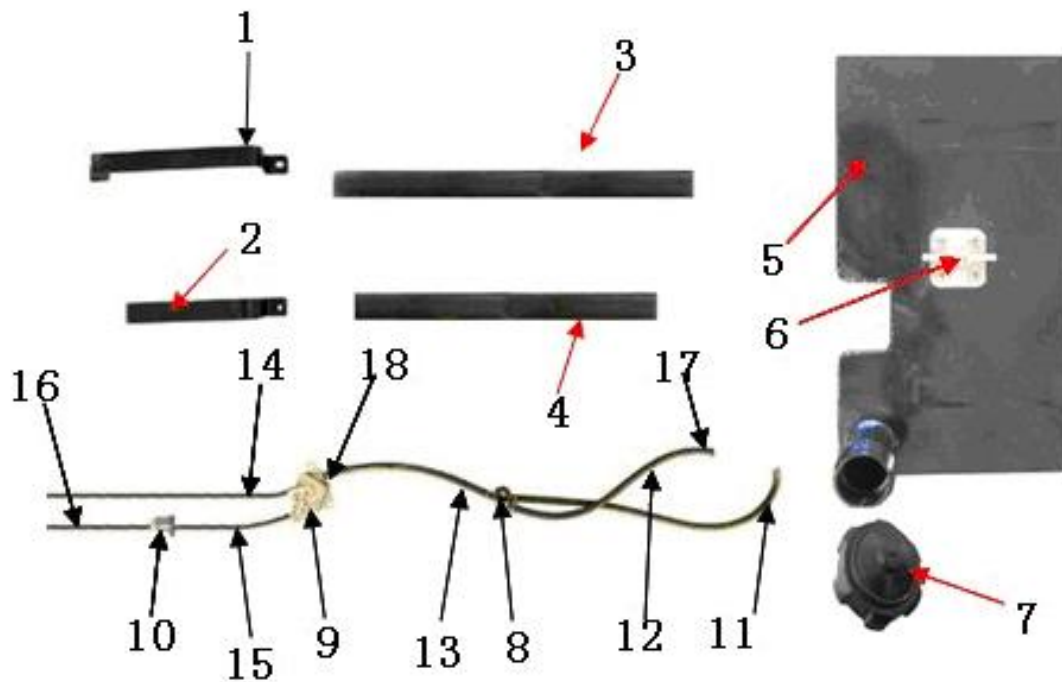
**FIG. 25 STEERING SHAFT ASSY.**



STEERING SHAFT ASSY			
REF NO.	PART NO.	DESCRIPTION	QTY
25-1	7.010.041	STEERING BOLT COVER	1
25-2	57830601210005	BOLT M6X12	3
25-5	6000122250G000	STEERING SHAFT	1
25-4	7.020.038	STEERING WHEEL	1
25-6	7.010.026	BUSH STEERING SHAFT	2
25-7	7.020.066	BALL JOINT DUST COVER	2
25-8	7.010.003	TILT STEERING LOCKING BUSHING	2

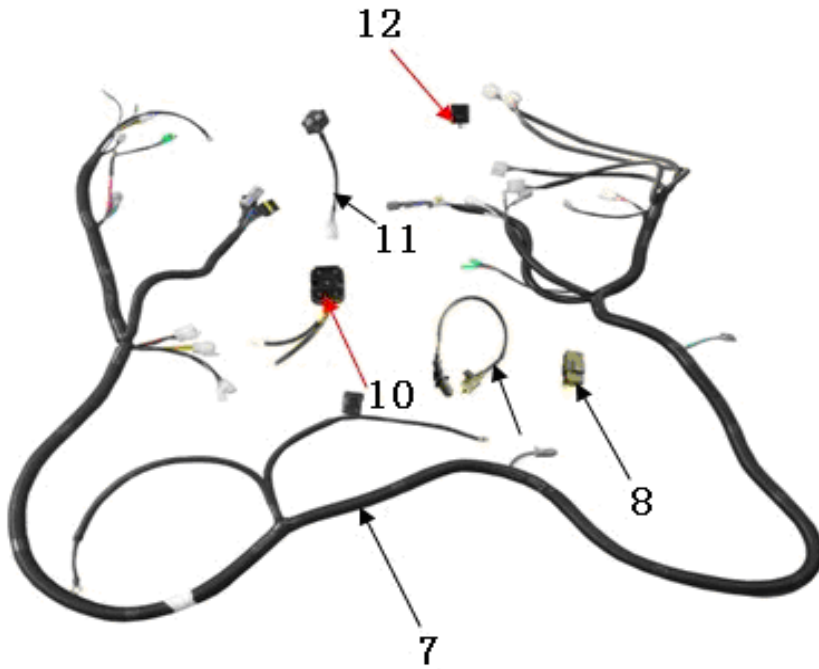
25-9	GB5782	BOLT M8x30	3
25-10	93000800000005	WASHER $\phi$ 8	2
25-11	40200-150U	steering link JOINT	1
25-13	57890801612505	BOLT M8X16	3
25-14	40300-150U	STEERING ASSY.	1
25-15	40303-150U	RIGHT TIE ROD	1
25-17	40950300k000	SSSTEERING ROD END	2
25-18	40302-150U	LEFT TIE ROD	2
25-19	43017N00S000	ROD END	2
25-20	97001000000005	WASHER $\phi$ 10	4
25-21	93001000000005	SPRING WASHER $\phi$ 10	4
25-22	94571000012505	CASTLE NUT M10X1.25	4
25-23	GB912502500002	COTTER PIN $\phi$ 2.5X25	4
25-24	4.000.051-150XRS	TILT STEERING HOUSING	1
25-26	61870800012505	LOCKING NUT M8	1
25-49	40001-150A	ADJUSTING BOLT	1
25-50	8.010.015	COLLAR	1
25-51	57890810512505	BOLT M8X105	1

FIG. 26 FUEL TANK



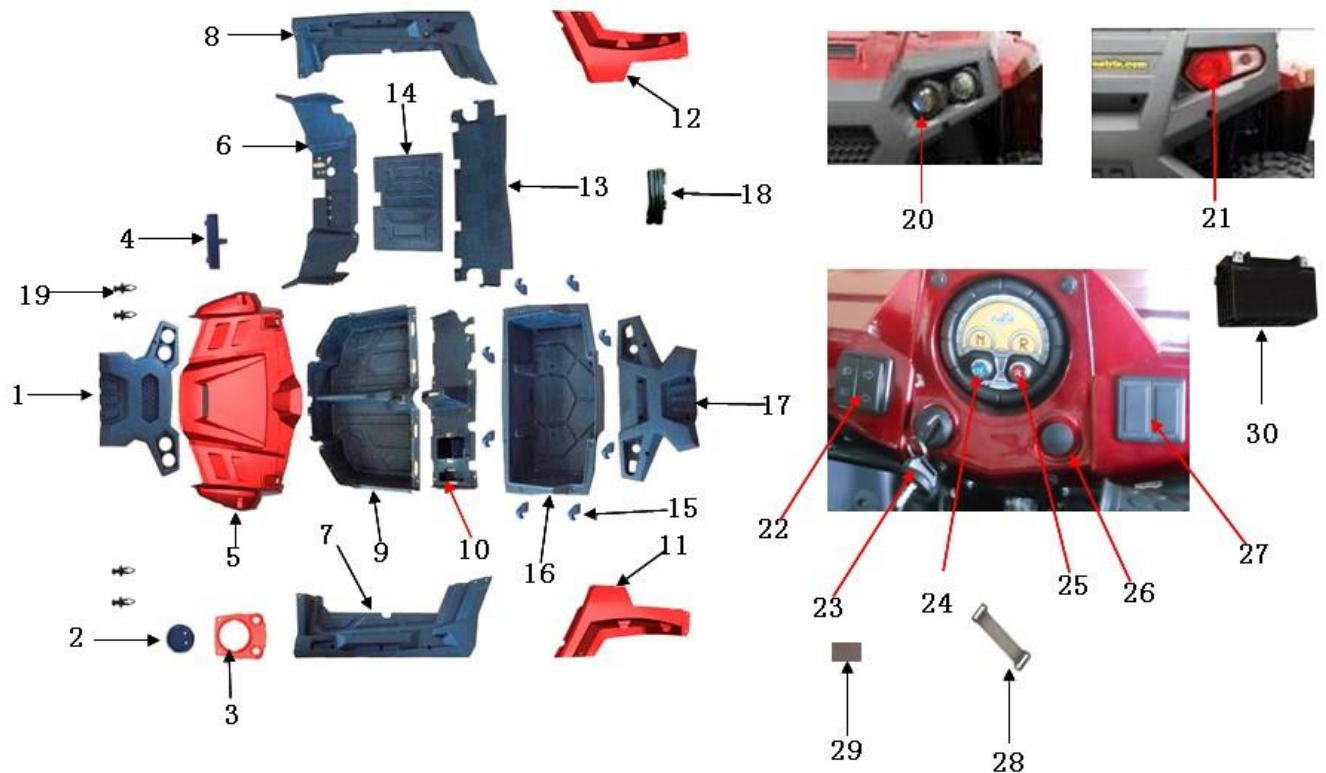
FUEL TANK			
REF NO.	PART NO.	DESCRIPTION	QTY
26-1	19-0400102	fuel tank clamp big	1
26-2	19-0400103	fuel tank clamp small	1
26-3	19-0400104	fuel tank rubber strip L=400	1
26-4	19-0400105	fuel tank rubber strip L=360	1
26-5	50010-150U	fuel tank	1
26-6	50020-150U	oil-out	1
26-7	19-0400101	fuel tank cap	1
26-8	19-0400107	fuel tank switch	1
26-9	19-0400106	fuel oil vacuum pump	1
26-10	19-0400110	petrol filter	1
26-11	19-0400111	oil pipe 1 $\Phi$ 6 L=590	1
26-12	19-0400112	oil pipe 2 $\Phi$ 6 L=400	1
26-13	19-0400113	oil pipe 3 $\Phi$ 6 L=310	1
26-14	19-0400114	oil pipe 4 $\Phi$ 4.5 L=460	1
26-15	19-0400115	oil pipe 5 $\Phi$ 4.5 L=300	1
26-16	19-0400116	oil pipe 6 $\Phi$ 4.5 L=240	1
26-17	04-0301010	fule tank clamp big	6
26-18	04-0403006	fule tank clamp small	6

**FIG. 27 ELECTRICAL PARTS**



<b>ELECTRICAL PARTS</b>			
REF NO.	PART NO.	DESCRIPTION	QTY
27-7	80025-150U	WIRE HARENESS	1
27-8	6000126150G000	CDI	1
27-9	6000125150G000	IGNITION COIL	1
27-10	6000124150G000	voltage regulator	1
27-11	6000035250G000	starting relay	1
27-12	6000153250G000	Flash apparatus	1

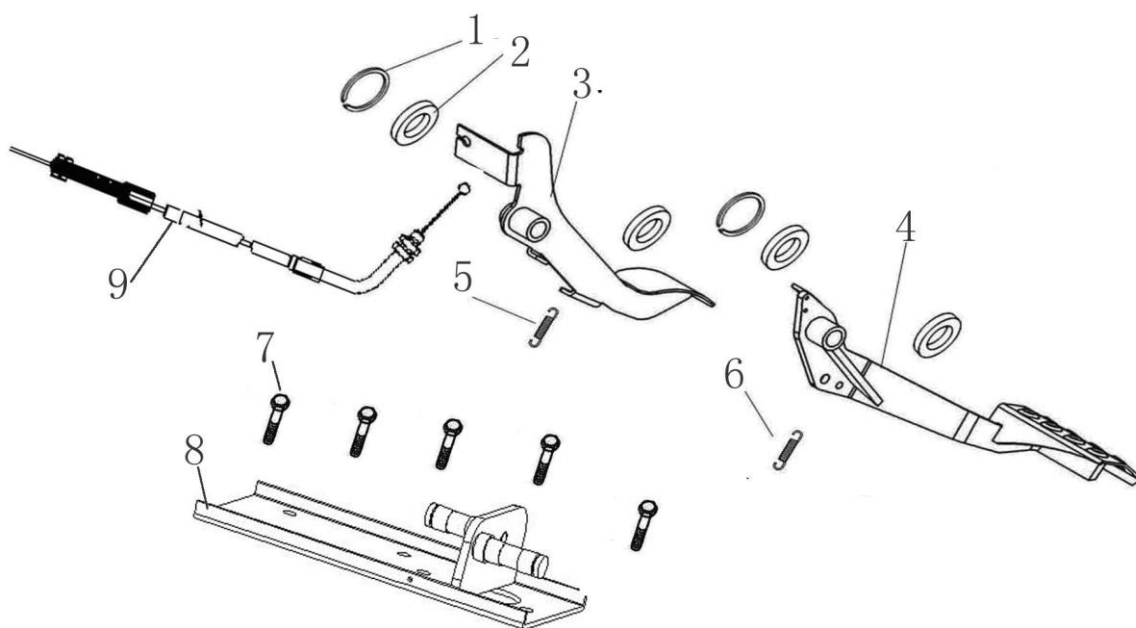
**FIG. 28 PLASTIC PARTS**



PLASTIC PARTS			
REF NO.	PART NO.	DESCRIPTION	QTY
28-1	19-1000101	front fender	1
28-2	19-1000102	fake instrument	1
28-3	19-1000103	instrument seat	1
28-4	19-1000104	air window	1
28-5	19-1000105	hood	1
28-6	19-1000106	front guard	1
28-7	19-1000107	left guard	1
28-8	19-1000108	right guard	1
28-9	19-1000109	footrest pedal	1
28-10	19-1000110	seat baseboard	1
28-11	19-1000111	left wheel arch	1
28-12	19-1000112	right wheel arch	1
28-13	19-1000113	back guard board	1
28-14	19-1000114	tank toe-board	1
28-15	19-1000115	pothook	8
28-16	19-1000116	TRUNK	1
28-17	19-1000117	rear fender	1
28-18	19-1000118	chain wheel guard	1
28-19	19-1000121	Snap	58

28-20	19-0900301	front light (with fog light)	2
28-20	19-0900302	front light	2
28-21	19-0900305	rear tail light left	1
28-21	19-0900306	rear tail light right	1
28-22	19-0900307	combination switch	1
28-23	19-0900201	switch lock	1
28-24	19-0900304	N light	1
28-25	19-0900303	R light	1
28-26	19-1000119	Plastic plug	1
28-27	19-1000120	combination switch spare plate	1
28-28	19-0900402	battery pull tie	1
28-29	19-0900401	battery cushion	2
28-30	04-0916000	battery	1

**FIG. 29 THROTTLE AND BRAKE**



THROTTLE AND BRAKE			
REF NO.	PART NO.	DESCRIPTION	QTY
29-1	9.700.015	CIRCLIP $\phi$ 15	2
29-2	GB95	FLAT WASHER $\phi$ 14	4
29-3	58230-150U	THROTTLE PEDAL COMP.	1
29-4	58270-150U	BRAKE PEDAL COMP.	1
29-5	58235N	THROTTLE PEDAL RETURN SPRING	1
29-6	58276N	BRAKE PEDAL RETURN SPRING	1
29-7	57870601612505	BOLT M6X16	1
29-8	58210-150U	BRAKE PEDAL SHELF	1